

ALL OF US  
WHO LIKE THE  
OPEN ROAD  
HAVE ONE THING  
IN COMMON:  
A LOVE  
OF FREEDOM

# ROAD





ORCA - ONIX - LOBULAR - AQUA - FITNESS - CICLOCROSS

The feeling of running non-stop like an engine, and that with just our bike for company we can go anywhere. Orbea knows how you feel, and we work so that you will never lose that love of freedom. We offer you a range of bikes and we're sure you'll find the one for you among them: the bike that'll get you to your destination, the bike that'll carry you as far as your imagination wants to go. Because we know you, and we know what we're doing. Horizons are just steps on a new path, crossroads are just new options for making the most of what you're mad about. Do you want freedom? Choose Orbea.

# ARGUMENTATION



## 01. PRODUCT ID

NAME	Orbea Orca
USE	Gold: Competition Silver: competition- sports
CONSTRUCTION	OMG (Orbea Monocoque Gold) and OMS (Orbea Monocoque Silver)
MATERIALS	Orbea Carbon Gold and Silver; Carbon frame
WARRANTY	Lifetime
DESIGN	ORBEA DESIGN
TECHNOLOGY	   

## 02. BENEFITS

### Who is the new Orca designed for?

Orca is synonymous with competition. From the day it leaves our carbon moulds it continues to prove that it is one of the elite bikes on the ProTour due to innovation, design, technology and Orbea know-how and our long heritage in competitive cycling. Not only do professionals need the best bike, Orbea pwners world wide, who slip on their jersey, helmet and shoes and set out to conquer new challenges. Long rides and races where, as in the ProTour, a bike is needed that allows maximum performance and optimum transfer of power in each pedal stroke.

### Why is the new Orca among the best in competitive cycling?

Orbea's professional athletes and our dedicated group of engineers and designers, work closely together to determine what is required and requested from a bicycle to be the very best. The application of our latest technology such as SSN, Attraction, DCR and AlZonE is the result of our experience from collaborating with the top athletes in the sport of professional cycling.

### Who uses it?

- Euskaltel-Euskadi
- Andalucía Cajasur
- Orbea Continental
- Kelly Benefits (USA)

### What is the global warranty for the new Orca?

The new Orca is backed by the solvency, guarantee and quality demonstrated by the Orbea Engineering Department. Its lifetime warranty comes after thorough UNE standards testing in our Quality Department.

### What differentiates Orbea from other brands?

Our commitment. The peace of mind given by a brand that ensures that your only concern when riding will be the weather. We'd like to offer you the best product, the best service and the best technical support so nothing will hold you back. That does not happen overnight. This is only achieved through years of work and listening to our customers. Our Orbea Stores and global dealers are ready to accompany you on your route. In short, so you never stop riding.

Orbea will also let you design your own bike. Your wish is our desire. Through our online MyO system, Orbea offers you twelve colors and numerous assembly options so that you can create the Orbea of your dreams.

## 03. STRONG POINTS

### SSN TECHNOLOGY



Introducing the evolution of our Size Specific Nerve technology. Initially, Orbea engineers created this technology to optimize the structure of the frame according to the different sizes offered. After four years in the market, the SSN technology applied to the 2011 Orca represents a qualitative leap in the design and creation of frames.

### ATTRACTION



Attraction is the smoothness all cyclists desire. Remove road interactions with the body to obtain the best performance. Optimizing the displacement of power to the wheels. Developing more control over the machine for the road. Enhanced traction regardless of terrain or weather. That's Attraction.

### DCR TECHNOLOGY



We have created a unique cable-routing system that very efficiently routes the cable paths to the brakes and derailleurs. Created by Orbea in 2010 as a key design element of the second generation Alma, we have introduced this innovation to the Orca because of its efficient response at all levels, its smoothness of operation and the ultra clean lines it gives the design. Cables are protected from the elements, minimizing friction and multiplying durability.

### AIzonE BY ORBEA



The Aizone Project (Aerodynamic Investigation Zone) developed in the San Diego Low Speed Wind Tunnel, has enabled Orbea to achieve extensive knowledge on aerodynamics. Thus, on the new Orca we have optimized the aerodynamics by 14%. I.e., we have reduced the drag or frictional surface, achieving a faster and more stable bike.

### CARBON GSB



Orbea Carbon is a composite comprising of high modulus carbon fibers which create structures with optimum stiffness, strength, lightness and vibration absorption. Ultimately, the best qualities to create the perfect frames.

### MONOCOQUE TECHNOLOGY



The stress is divided out in an optimal manner, throughout the entire structure, there are no joints, no points of union and therefore the critical areas are minimized. The means your frame can withstand as many kilometers as you desire.

### ORBEA DESIGN



Orbea Design is based on, what are for us, the four essential elements in the design of a bicycle: bicycle lovers, the most modern technology, the process of creation and design trends. The logo we have chosen for the Orbea Design explains this perfectly: each one of these concepts forms the centerpiece of our work.

## 04. COMPARATIVE



	Orca G	Orca S
Gold Carbon Fiber	•	
Silver Carbon Fiber		•
SSN Technology	•	•
AIzonE	•	•
DCR	•	•
Attraction	•	•
Monocoque	•	•
BB30	•	•
Oversize Headtube	•	•
Carbon frame and fork dropouts	•	•
Customized aluminum parts	•	
Orbea Design	•	•
Monolink	•	



### Orca .GD2

-  ORBEA ORCA GOLD Di2
-  ORBEA ORCA GOLD
-  SHIMANO DURA ACE Di2
-  LIGHT WEIGHT STD III CL
-  48/51/53/55/57/60
-  CARBON ORANGE

## Orca

### Orca Gold

Take a good look at this bike. It is not a product, it is a feeling. It's competition. It is the adrenalin of the Tour converted into carbon, the sweat of the Giro converted into technology, the tension of the key stage of La Vuelta transformed into innovation... We worked side by side with our cycling team and we asked them to dream. We have tried to create the bike of our dreams, of your dreams. And we have created realities. Breathe deeply, it's just a bike.





### Orca .GDR

-  ORBEA ORCA GOLD
-  ORBEA ORCA GOLD
-  SHIMANO DURA ACE
-  SHIMANO DURA ACE CARBON
-  48/51/53/55/57/60
-  CARBON BLUE







*Orca* .GRC

 ORBEA ORCA GOLD	 48/51/53/55/57/60
 ORBEA ORCA GOLD	 CARBON SILVER
 CAMPAGNOLO SUPER RECORD	
 CAMPAGNOLO BORA	



*Orca* .GRD

 ORBEA ORCA GOLD	 48/51/53/55/57/60
 ORBEA ORCA GOLD	 CARBON WHITE
 SRAM RED	
 ZIPP 404 CLINCHER	

## SPECIFICATIONS



CHARACTERISTICS	<i>Orca</i> .GDi2	<i>Orca</i> . GDR	<i>Orca</i> . GRC
<b>FRAME</b>	ORBEA ORCA GOLD Di2	ORBEA ORCA GOLD	ORBEA ORCA GOLD
<b>FORK</b>	ORBEA ORCA GOLD	ORBEA ORCA GOLD	ORBEA ORCA GOLD
<b>CRANKSET</b>	SHIMANO DURA ACE 34x50 CT	SHIMANO DURA ACE 34x50 CT	CAMPAGNOLO S RECORD 34x50 CT
<b>HEADSET</b>	INTEGRATED CARBON 1 1/2	INTEGRATED CARBON 1 1/2	INTEGRATED CARBON 1 1/2
<b>HANDLEBAR</b>	ORBEA WING CARBON	ORBEA WING CARBON	ORBEA WING CARBON
<b>STEM</b>	ORBEA CARBON PRO	ORBEA CARBON PRO	ORBEA CARBON PRO
<b>SHIFTERS</b>	SHIMANO DURA ACE Di2	SHIMANO DURA ACE	CAMPAGNOLO SUPER RECORD
<b>BRAKES</b>	SHIMANO DURA ACE	SHIMANO DURA ACE	CAMPAGNOLO SUPER RECORD
<b>REAR DERAILLEUR</b>	SHIMANO DURA ACE Di2	SHIMANO DURA ACE	CAMPAGNOLO SUPER RECORD
<b>FRONT DERAILLEUR</b>	SHIMANO DURA ACE Di2	SHIMANO DURA ACE	CAMPAGNOLO SUPER RECORD
<b>CHAIN</b>	SHIMANO DURA ACE	SHIMANO DURA ACE	SUPER RECORD
<b>WHEELS</b>	LIGHT WEIGHT STD III CL	SHIMANO DURA ACE CARBON	CAMPAGNOLO BORA
<b>REAR COGS</b>	SHIMANO DURA ACE 12-25 10S	SHIMANO DURA ACE 12-25 10S	CAMPAGNOLO S RECORD 12-25 11S
<b>TYRES</b>	MICHELIN PRO3 RACE 700x23	MICHELIN PRO3 RACE 700x23	VITTORIA CORSA EVOCX 700x21
<b>PEDALS</b>	SHIMANO DURACE	SHIMANO DURACE	LOOK KEO CARBON
<b>SEAT POST</b>	ORBEA ORCA MONOLINK	ORBEA ORCA MONOLINK	ORBEA ORCA MONOLINK
<b>SADDLE</b>	SELLE ITALIA SLR MONOLINK	SELLE ITALIA SLR MONOLINK	SELLE ITALIA SLR MONOLINK

OPTIONS	<i>Orca</i> .GDi2	<i>Orca</i> . GDR	<i>Orca</i> . GRC
<b>CRANKSET</b>	SHIMANO DURA ACE 39x53 FSA K-FORCE 39x53 BB30 FSA K-FORCE 34x50 BB30	SHIMANO DURA ACE 39x53 FSA K-FORCE 39x53 BB30 FSA K-FORCE 34x50 BB30	CAMPAGNOLO SRECORD 39x53 FSA K-FORCE 39x53 BB30 FSA K-FORCE 34x50 BB30
<b>HANDLEBAR</b>	FSA K-FORCE	FSA K-FORCE	FSA K-FORCE
<b>STEM</b>	FSA OS-99 CSI -	FSA OS-99 CSI -	FSA OS-99 CSI -
<b>WHEELS</b>	ZIPP 303 ZIPP 404 SHIMANO WH-7900 C24 MAVIC KSYRIUM SL SHIMANO WH-7900 C35 MAVIC COSMIC CARBON SL -	ZIPP 303 ZIPP 404 - SHIMANO WH-7900 C24 MAVIC KSYRIUM SL LIGHTWEIGHT STANDARD C MAVIC COSMIC CARBON SL -	ZIPP 404 LIGHTWEIGHT STANDARD C ZIPP 303 MAVIC COSMIC CARBON SL MAVIC KSYRIUM SL - - -
<b>PEDALS</b>	LOOK KEO CARBON	LOOK KEO CARBON	-
<b>SADDLE</b>	-	-	-

## GEOMETRY

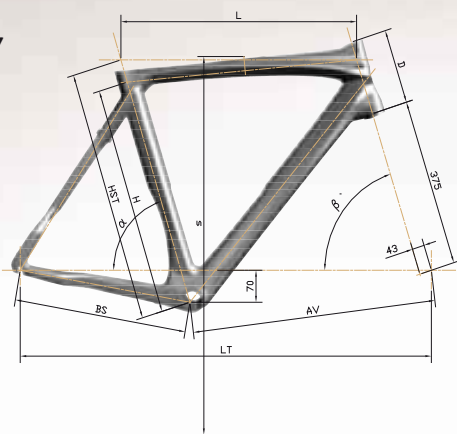

SIZES	HST	H	L	D	BS	AV	LT	S	$\alpha$	$\beta$
48	480	430	520	104	405	575	970	743	74.75°	71.5°
51	510	460	535	120	405	575	970	766	73.5°	72.1°
53	530	480	545	145	405	585	980	788	73.5°	72.1°
55	550	500	555	165	408	590	988	807	73.2°	72.4°
57	570	520	570	185	408	600	998	827	73.2°	72.9°
60	600	550	590	205	408	615	1013	846	73.2°	73.5°

Orca . GRD

ORBEA ORCA GOLD
ORBEA ORCA GOLD
SRAM RED 34x50 BB30 CT
INTEGRATED CARBON 1 1/2
ORBEA WING CARBON
ORBEA CARBON PRO
SRAM RED
SRAM RED
SRAM RED
SRAM RED
SRAM PC 1090
ZIPP 404 CLINCHER
SRAM OG-1090 11-26 10S
MICHELIN PRO3 RACE 700x23
LOOK KEO CARBON
ORBEA ORCA MONOLINK
SELLE ITALIA SLR MONOLINK

Orca . GRD

SRAM RED 39x53 BB30
FSA K-FORCE 39x53 BB30
FSA K-FORCE 34x50 BB30
FSA K-FORCE
FSA OS-99 CSI
-
ZIPP 303
MAVIC KSYRIUM SL
LIGHTWEIGHT STANDARD C
-
MAVIC COSMIC CARBON SL
-
-
-
-
-

COLOURS



COLOUR	Orca GRD	Orca GRC	Orca GDi2	Orca GDR
<b>CARBON WHITE</b> Ref: X1				
<b>CARBON SILVER</b> Ref: X2				
<b>CARBON ORANGE</b> Ref: X3				
<b>CARBON BLUE</b> Ref: X4				

ARGUMENTATION



01. PRODUCT ID

NAME	Orbea Orca
USE	Gold: Competition
CONSTRUCTION	OMG (Orbea Monocoque Gold)
MATERIALS	Orbea Carbon Gold; Carbon frame
WARRANTY	Lifetime
DESIGN	ORBEA DESIGN

TECHNOLOGY



02. BENEFITS

Who is the new Orca designed for?

Orca is synonymous with competition. From the day it leaves our carbon moulds it continues to prove that it is one of the elite bikes on the ProTour due to innovation, design, technology and Orbea know-how and our long heritage in competitive cycling. Not only do professionals need the best bike, Orbea owners world wide, who slip on their jersey, helmet and shoes and set out to conquer new challenges. Long rides and races where, as in the ProTour, a bike is needed that allows maximum performance and optimum transfer of power in each pedal stroke.

03. STRONG POINTS

SSN TECHNOLOGY	ATTRACTION	DCR TECHNOLOGY	AIZonE BY ORBEA
ORBEA CARBON GOLD	MONOCOQUE TECHNOLOGY	ORBEA DESIGN	

04. COMPARATIVE

	ORCA GOLD	ORCA SILVER
Gold Carbon Fiber	•	
Silver Carbon Fiber		•
SSN Technology	•	•
AIZonE	•	•
DCR	•	•
Attraction	•	•
Monocoque	•	•
BB30	•	•
Oversize Headtube	•	•
Carbon frame and fork dropouts	•	•
Customized aluminum parts	•	
Orbea Design	•	•
Monolink	•	





### *Orca* .SRD

-  ORBEA ORCA SILVER
-  ORBEA ORCA SILVER
-  SHIMANO DURA ACE
-  MAVIC KSYRIUM ELITE
-  48/51/53/55/57/60
-  WHITE RED SILVER

## *Orca*

### Orca Silver

At first glance it's just a bike. When you ride it you see that everything flows. Technology becomes your ally. Orca will be an icon in your life. Your escape route. The competition in your hands. Discover how we have been able to improve the unsurpassable, to re-invent one of the best bikes in history. Breathe deeply, it's just a bike.





### *Orca* .SRC

-  ORBEA ORCA SILVER
-  ORBEA ORCA SILVER
-  CAMPAGNOLO SUPER RECORD
-  MAVIC KSYRIUM ELITE
-  48/51/53/55/57/60
-  SILVER CARBON RED



*Orca* .SDR

-  ORBEA ORCA SILVER
  -  ORBEA ORCA SILVER
  -  SRAM RED
  -  MAVIC KSYRIUM ELITE
- SIZE 48/51/53/55/57/60
-  WHITE CARBON ORANGE



*Orca* .SFR

-  ORBEA ORCA SILVER
  -  ORBEA ORCA SILVER
  -  SRAM FORCE
  -  MAVIC KSYRIUM EQUIPE
- SIZE 48/51/53/55/57/60
-  WHITE CARBON GREEN



*Orca* .SCN

-  ORBEA ORCA SILVER
  -  ORBEA ORCA SILVER
  -  CAMPAGNOLO CENTAUR
  -  MAVIC KSYRIUM EQUIPE
- SIZE 48/51/53/55/57/60
-  SILVER CARBON RED



*Orca* .SLT

-  ORBEA ORCA SILVER
  -  ORBEA ORCA SILVER
  -  SHIMANO ULTEGRA
  -  MAVIC KSYRIUM EQUIPE
- SIZE 48/51/53/55/57/60
-  WHITE RED SILVER

## SPECIFICATIONS



CHARACTERISTICS	<i>Orca</i> . SRD	<i>Orca</i> . SRC	<i>Orca</i> . SDR	<i>Orca</i> . SFR
<b>FRAME</b>	ORBEA ORCA SILVER	ORBEA ORCA SILVER	ORBEA ORCA SILVER	ORBEA ORCA SILVER
<b>FORK</b>	ORBEA ORCA SILVER	ORBEA ORCA SILVER	ORBEA ORCA SILVER	ORBEA ORCA SILVER
<b>CRANKSET</b>	SHIMANO DURA ACE 34x50 CT	CAMPAGNOLO S RECORD 34x50 CT	SRAM RED 34x50 BB30 CT	SRAM FORCE BB30 34x50 CT
<b>HEADSET</b>	INTEGRATED CARBON 1 1/2	INTEGRATED CARBON 1 1/2	INTEGRATED CARBON 1 1/2	INTEGRATED CARBON 1 1/2
<b>HANDLEBAR</b>	ORBEA WING ALU	ORBEA WING ALU	ORBEA WING ALU	ORBEA WING ALU
<b>STEM</b>	ORBEA CARBON ALU	ORBEA CARBON ALU	ORBEA CARBON ALU	ORBEA CARBON ALU
<b>SHIFTERS</b>	SHIMANO DURA ACE	CAMPAGNOLO SUPER RECORD	SRAM RED	SRAM FORCE
<b>BRAKES</b>	SHIMANO DURA ACE	CAMPAGNOLO SUPER RECORD	SRAM RED	SRAM FORCE
<b>REAR DERAILLEUR</b>	SHIMANO DURA ACE	CAMPAGNOLO SUPER RECORD	SRAM RED	SRAM FORCE
<b>FRONT DERAILLEUR</b>	SHIMANO DURA ACE	CAMPAGNOLO SUPER RECORD	SRAM RED	SRAM FORCE
<b>CHAIN</b>	SHIMANO DURA ACE	SUPER RECORD	SRAM PC 1090	KMC DX-10
<b>WHEELS</b>	MAVIC KSYRIUM ELITE	MAVIC KSYRIUM ELITE	MAVIC KSYRIUM ELITE	MAVIC KSYRIUM EQUIPE
<b>REAR COGS</b>	SHIMANO DURA ACE 12-25 10S	CAMPAGNOLO S RECORD 12-25 11S	SRAM OG-1090 11-26 10S	SRAM 12-25 10S
<b>TYRES</b>	VITTORIA RUBINO PRO 700x23	VITTORIA RUBINO PRO 700x23	VITTORIA RUBINO PRO 700x23	VITTORIA RUBINO PRO 700x23
<b>PEDALS</b>	LOOK KEO CARBON	LOOK KEO CARBON	LOOK KEO CARBON	LOOK KEO CARBON
<b>SEAT POST</b>	ORBEA ORCA	ORBEA ORCA	ORBEA ORCA	ORBEA ORCA
<b>SADDLE</b>	SELLE ITALIA SLR XP FLOW	SELLE ITALIA SLR XP FLOW	SELLE ITALIA SLR XP FLOW	SELLE ITALIA SLR XP FLOW

OPTIONS	<i>Orca</i> . SRD	<i>Orca</i> . SRC	<i>Orca</i> . SDR	<i>Orca</i> . SFR
<b>CRANKSET</b>	FSA K-FORCE 34x50 BB30 FSA K-FORCE 39x53 BB30 SHIMANO DURA ACE 39x53	SUPER RECORD 39x53 FSA K-FORCE 39x53 BB30 FSA K-FORCE 34x50 BB30	SRAM RED 39x53 FSA K-FORCE 34x50 BB30 FSA K-FORCE 39x53 BB30	SRAM FORCE 39x53 BB30 FSA K-FORCE 34x50 BB30 FSA K-FORCE 39x53 BB30
<b>HANDLEBAR</b>	FSA K-FORCE	FSA K-FORCE	FSA K-FORCE	FSA K-FORCE BAR
<b>STEM</b>	FSA OS-99 CSI ORBEA CARBON PRO	FSA OS-99 CSI ORBEA CARBON PRO	FSA OS-99 CS ORBEA CARBON PRO	FSA OS-99 CSI ORBEA CARBON PRO
<b>WHEELS</b>	ZIPP 404 ZIPP 303 SHIMANO WH-7900 C24 CL - SHIMANO WH-RS80 CARBON MAVIC KSYRIUM SL MAVIC COSMIC CARBON SL	ZIPP 303 ZIPP 404 MAVIC KSYRIUM SL CAMPAGNOLO BORA MAVIC COSMIC CARBON SL - -	ZIPP 303 ZIPP 404 MAVIC KSYRIUM SL MAVIC COSMIC CARBON SL - -	ZIPP 404 ZIPP 303 MAVIC KSYRIUM SL MAVIC KSYRIUM ELITE MAVIC COSMIC CARBON SL - -
<b>PEDALS</b>	SHIMANO DURA ACE	-	-	-
<b>SADDLE</b>	SELLE ITALIA FLITE GEL FLOW	SELLE ITALIA FLITE GEL FLOW	SELLE ITALIA FLITE GEL FLOW	SELLE ITALIA FLITE GEL FLOW

## GEOMETRY

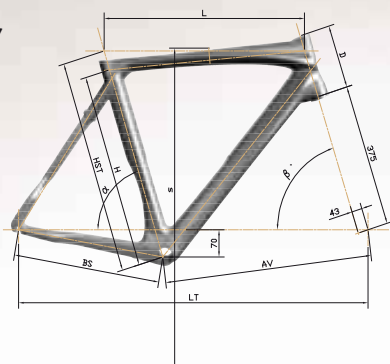

SIZES	HST	H	L	D	BS	AV	LT	S	$\alpha$	$\beta$
48	480	430	520	104	405	575	970	743	74.75°	71.5°
51	510	460	535	120	405	575	970	766	73.5°	72.1°
53	530	480	545	145	405	585	980	788	73.5°	72.1°
55	550	500	555	165	408	590	988	807	73.2°	72.4°
57	570	520	570	185	408	600	998	827	73.2°	72.9°
60	600	550	590	205	408	615	1013	846	73.2°	73.5°

## ARGUMENTATION



### 01. PRODUCT ID

NAME	Orbea Orca
USE	Competition- sports
CONSTRUCTION	OMS (Orbea Monocoque Silver)
MATERIALS	Orbea Carbon Silver; Carbon frame
WARRANTY	Lifetime Warranty
DESIGN	Integrated design of parts: cable routing Twin Clamp; hand painted

#### TECHNOLOGY



### 02. BENEFITS

#### Who is the new Orca designed for?

Orca is synonymous with competition. From the day it leaves our carbon moulds it continues to prove that it is one of the elite bikes on the ProTour due to innovation, design, technology and Orbea know-how and our long heritage in competitive cycling. Not only do professionals need the best bike, Orbea owners world wide, who slip on their jersey, helmet and shoes and set out to conquer new challenges. Long rides and races where, as in the ProTour, a bike is needed that allows maximum performance and optimum transfer of power in each pedal stroke.

### 03. STRONG POINTS

#### SSN TECHNOLOGY



#### ORBEA CARBON SILVER



#### MONOCOQUE TECHNOLOGY



#### ORBEA DESIGN



#### BB30 TECHNOLOGY



#### OVERSIZE HEADTUBE



### Orca . SCN

ORBEA ORCA SILVER	ORBEA ORCA SILVER
ORBEA ORCA SILVER	ORBEA ORCA SILVER
CAMPAGNOLO CENTAUR 34x50 CT	SHIMANO ULTEGRA 34x50 CT
INTEGRATED CARBON 1 1/2	INTEGRATED CARBON 1 1/2
ORBEA WING ALU	ORBEA WING ALU
ORBEA CARBON ALU	ORBEA CARBON ALU
CAMPAGNOLO CENTAUR	SHIMANO ULTEGRA
CAMPAGNOLO CENTAUR	SHIMANO ULTEGRA
CAMPAGNOLO CENTAUR	SHIMANO ULTEGRA
CAMPAGNOLO CENTAUR	SHIMANO ULTEGRA
KMC DX-10	SHIMANO ULTEGRA
MAVIC KSYRIUM EQUIPE	MAVIC KSYRIUM EQUIPE
CAMPAGNOLO CENTAUR 12-25 10S	SHIMANO ULTEGRA 12-25 10S
VITTORIA RUBINO PRO 700x23	VITTORIA RUBINO PRO 700x23
LOOK KEO CARBON	LOOK KEO CARBON
ORBEA ORCA	ORBEA ORCA
SELLE ITALIA SLR XP FLOW	SELLE ITALIA SLR XP FLOW

### Orca . SCN

CAMPAGNOLO CENTAUR 39x53	FSA K-FORCE 34x50 BB30
FSA K-FORCE 34x50 BB30	FSA K-FORCE 39x53 BB30
FSA K-FORCE 39x53 BB30	-
FSA K-FORCE	FSA K-FORCE
FSA OS-99 CSI	FSA OS-99 CSI
ORBEA CARBON PRO	ORBEA CARBON PRO
ZIPP 404	ZIPP 404
ZIPP 303	ZIPP 303
MAVIC KSYRIUM ELITE	-
MAVIC KSYRIUM SL	SHIMANO WH-RS80 CARBON
MAVIC COSMIC CARBON SL	MAVIC KSYRIUM SL
-	MAVIC KSYRIUM ELITE
-	MAVIC COSMIC CARBON SL
-	-
SELLE ITALIA FLITE GEL FLOW	SELLE ITALIA FLITE GEL FLOW

### Orca . SLT

### Orca . SLT

## COLOURS



Ref.:XA WHITE CARBON ORANGE



Orca SRD  
Orca SRC  
Orca SDR  
Orca SFR  
Orca SCN  
Orca SLT

Ref.:XB WHITE RED SILVER



Orca SRD  
Orca SRC  
Orca SDR  
Orca SFR  
Orca SCN  
Orca SLT

Ref.:XD WHITE CARBON GREEN



Orca SRD  
Orca SRC  
Orca SDR  
Orca SFR  
Orca SCN  
Orca SLT

Ref.:XE SILVER CARBON RED



Orca SRD  
Orca SRC  
Orca SDR  
Orca SFR  
Orca SCN  
Orca SLT

# ARGUMENTATION



## 01. PRODUCT ID

NAME	Orbea Onix
USE	Sport leisure
CONSTRUCTION	Orbea Monocoque
MATERIALS	Orbea Carbon Bronze, stops and cable guides in 7000 aluminium
WARRANTY	Lifetime Warranty
DESIGN	Hand-painted in a choice
TECHNOLOGY	

## 02. BENEFITS

### Who is the Onix designed for?

The first level in Orbea carbon bikes is a delight for the senses and a real experience gatherer. This is a fully-guaranteed bicycle designed for those who feel at home on the road, who like big distances and enjoying the route to the full.

Because the road belongs to you and you don't settle for the basics other brands give you: you want it all. Because cycling mad, you like getting the race going and riding with your friends. And you know that to do all that, you need a reliable bike, to really make the most of your rides.

### Who rides it?

- Andalucía Elite
- Orbea América
- Naturgás Energía

### Recommended by?

We could talk about how the Onix is backed by the solid reputation, guarantee and quality demonstrated by the Orbea Engineering Department. Or that it's tested in accordance with UNE standards at our Quality Department.

But we prefer to tell how that it's the bikers themselves who certify the composure, durability and efficiency of the Onix. And that the amateur teams where future champions make their way ride the Onix.

### Why Orbea?

Orbea offers you the possibility of designing your own bike. You have a dream and we can make it come true. Orbea offers you five models, four colours, numerous assembly options and you can even customise your bike by putting your name on it. In short, a bike created for you and by you.



## 03. STRONG POINTS

### SSN TECHNOLOGY



Each bike size is designed individually, optimising the frame structure according to the stiffness ratio and the cyclist's body mass. The result is five individually-designed frames, 100% exclusive and perfectly balanced.

### LIFETIME WARRANTY



Orbea provides a lifetime guarantee on all its frames. Only a brand that knows the materials, masters the technologies and has the skills can guarantee your frame to be totally reliable. Only Orbea takes you a step beyond.

### ORBEA DESIGN



Orbea Design is based on what we consider the four essential elements of bicycle design: the riders, the state-of-the-art technology, the creation process and the trends. The logo we have chosen for Orbea Design explains it perfectly: each of these concepts is a key feature of the way we work.

### My Orbea



Orbea offers you the possibility of designing your own bike. You have a dream and we can make it come true. We're here to help you choose. Orbea offers you options for colour, assembly, size and ergonomics: transmission, handlebar width, crank length, seatpost length... in short, it adapts to you, it's created by you and for you.

### HAND-PAINTED

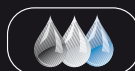

Our painting installations comply with current and future environmental protection legislation, and we use water-based paints, recycling the water used by the system. We are the only European bicycle sector company that uses this painting technology. The quality of our finishes and paintwork is exceptional.

### ORBEA CARBON BRONZE



Orbea Carbon Bronze fibres are intermediate module fibres that seek maximum performance by combining elasticity, durability and creating a frame accessible to anyone.



**onix**. CLT

-  ORBEA ONIX
-  ORBEA ORCA
-  SHIMANO ULTEGRA
-  MAVIC KSYRIUM ELITE
-  48/51/54/57/60
-  WHITE SILVER

# onix

Getting on an Onix is like opening the door to a whole world of sensations: the perfect day for a ride, the sun beaming down, the challenge of a mountain pass before you... We've created this bike with Bronze carbon fibres to guarantee you better performance and better efficiency. Its monocoque construction, great stiffness and SSN Tech make it completely unique, whatever the distance you want to travel.





**ORBEA ONIX . TLT**

ORBEA ONIX	48/51/54/57/60
ORBEA AC	CARBON WHITE
SHIMANO ULTEGRA	
MAVIC RS20	



**ORBEA ONIX . T105**

ORBEA ONIX	48/51/54/57/60
ORBEA AC	WHITE RED
SHIMANO 105	
MAVIC AKSIUM BLACK	



**ORBEA ONIX . TCN**

ORBEA ONIX	48/51/54/57/60
ORBEA AC	WHITE BLUE
CAMPAGNOLO CENTAUR	
MAVIC AKSIUM BLACK	



**ORBEA ONIX . TTG**

ORBEA ONIX	48/51/54/57/60
ORBEA AC	WHITE SILVER
SHIMANO TIAGRA	
SHIMANO WH-R500 BLACK	



## SPECIFICATIONS

enix

CHARACTERISTICS	enix . CLT	enix . TLT	enix . T105
<b>FRAME</b>	ORBEA ONIX	ORBEA ONIX	ORBEA ONIX
<b>FORK</b>	ORBEA ORCA	ORBEA AC	ORBEA AC
<b>CRANKSET</b>	SHIMANO ULTEGRA 34x50 CT	SHIMANO ULTEGRA 34x50 CT	SHIMANO 105 34x50 CT
<b>HEADSET</b>	INTEGRATED 1 1/8	INTEGRATED 1 1/8	INTEGRATED 1 1/8
<b>HANDLEBAR</b>	ORBEA WING ALU	ORBEA ALU PRO	ORBEA ALU PRO
<b>STEM</b>	ORBEA CARBON ALU	ORBEA ALU PRO	ORBEA ALU PRO
<b>SHIFTERS</b>	SHIMANO ULTEGRA	SHIMANO ULTEGRA	SHIMANO 105
<b>BRAKES</b>	SHIMANO ULTEGRA	SHIMANO ULTEGRA	SHIMANO 105
<b>REAR DERAILLEUR</b>	SHIMANO ULTEGRA	SHIMANO ULTEGRA	SHIMANO 105
<b>FRONT DERAILLEUR</b>	SHIMANO ULTEGRA	SHIMANO ULTEGRA	SHIMANO 105
<b>CHAIN</b>	SHIMANO ULTEGRA	SHIMANO ULTEGRA	SHIMANO 105
<b>WHEELS</b>	MAVIC KSYRIUM ELITE	MAVIC RS20	MAVIC AKSIUM BLACK
<b>REAR COGS</b>	SHIMANO ULTEGRA 12-25 10S	SHIMANO ULTEGRA 12-25 10S	SHIMANO 105 12-25 10S
<b>TYRES</b>	VITTORIA RUBINO 700x23	VITTORIA RUBINO 700x23	VITTORIA ZAFIRO 700x23
<b>PEDALS</b>	LOOK KEO EASY	LOOK KEO EASY	LOOK KEO EASY
<b>SEAT POST</b>	ORBEA CARBON PRO 2	ORBEA CARBON	ORBEA CARBON
<b>SADDLE</b>	SELLE ITALIA SL FLOW	SELLE ITALIA SL FLOW	SELLE ITALIA SL FLOW

OPTIONS	enix . CLT	enix . TLT	enix . T105
<b>FORK</b>	-	ORBEA ORCA	ORBEA ORCA
<b>CRANKSET</b>	SHIMANO ULTEGRA 39x53 SHIMANO ULTEGRA 30x39x53	SHIMANO ULTEGRA 30x39x53 SHIMANO ULTEGRA 39x53	SHIMANO FC553 30x39x50 SHIMANO FC550 39x53
<b>HANDLEBAR</b>	-	ORBEA WING ALU	ORBEA WING ALU
<b>STEM</b>	-	ORBEA CARBON ALU	ORBEA CARBON ALU
<b>WHEELS</b>	MAVIC KSYRIUM EQUIPE	MAVIC KSYRIUM EQUIPE	MAVIC KSYRIUM EQUIPE

## GEOMETRY

enix

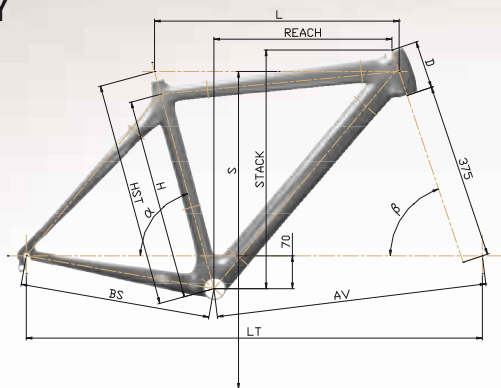

SIZES	HST	H	L	D	BS	AV	LT	S	α	β	Reach	Stack
48	480	430	520	102	405	57	970	720	74.75°	71.5°	360	500
51	510	460	535	122	405	557	970	750	73.5°	72.1°	377	530
54	540	490	550	152	408	558	983	780	73.2°	72.4°	379	559
57	570	520	570	182	408	560	998	810	73.2°	72.9°	391	590
60	600	550	590	212	408	615	1013	835	73.2°	73.5°	403	621

**ONIX . TCN**

ORBEA ONIX
ORBEA AC
CAMPAGNOLO CENTAUR 34x50 CT
INTEGRATED 1 1/8
ORBEA ALU PRO
ORBEA ALU PRO
CAMPAGNOLO CENTAUR
CAMPAGNOLO CENTAUR
CAMPAGNOLO CENTAUR
CAMPAGNOLO CENTAUR
KMC DX-10
MAVIC AKSIUM BLACK
CAMPAGNOLO CENTAUR 12-25 10S
VITTORIA RUBINO 700x23
LOOK KEO EASY
ORBEA CARBON
SELLE ITALIA SL FLOW

**ONIX . TTG**

ORBEA ONIX
ORBEA AC
SHIMANO TIAGRA 34x50 CT
INTEGRATED 1 1/8
ORBEA ALU PRO
ORBEA ALU PRO
SHIMANO TIAGRA
ORBEA PRO
SHIMANO TIAGRA
SHIMANO TIAGRA
SHIMANO HG53
SHIMANO WH-R500 BLACK
SHIMANO TIAGRA 12-25 9S
VITTORIA ZAFIRO 700x23
LOOK KEO EASY
ORBEA CARBON
SELLE ITALIA SL FLOW

**ONIX . TCN**

ORBEA ORCA
CAMPAGNOLO CENTAUR 39x53
-
ORBEA WING ALU
ORBEA CARBON ALU
MAVIC KSYRIUM ELITE
-

**ONIX . TTG**

ORBEA ORCA
SHIMANO TIAGRA 30x39x50
SHIMANO TIAGRA 39x52
ORBEA WING ALU
ORBEA CARBON ALU
MAVIC KSYRIUM EQUIPE
MAVIC AKSIUM RACE BLACK

ARGUMENTATION



01. PRODUCT ID

NAME	Orbea Onix
USE	Sport leisure
CONSTRUCTION	Orbea Monocoque
MATERIALS	Orbea Carbon Bronze, stops and cable guides in 7000 aluminium
WARRANTY	Lifetime Warranty
DESIGN	Hand-painted in a choice

TECHNOLOGY

02. BENEFITS

Who is the Onix designed for?

The first level in Orbea carbon bikes is a delight for the senses and a real experience gatherer. This is a fully-guaranteed bicycle designed for those who feel at home on the road, who like big distances and enjoying the route to the full.

Because the road belongs to you and you don't settle for the basics other brands give you: you want it all. Because cycling mad, you like getting the race going and riding with your friends. And you know that to do all that, you need a reliable bike, to really make the most of your rides.

03. STRONG POINTS

SSN TECHNOLOGY 	WARRANTY ORBEA 	ORBEA DESIGN 
MyO 	PINTADO A MANO 	ORBEA CARBON BRONZE 

COLOURS







CARBON WHITE Ref.: SW		Onix CLT	Onix TLT	Onix T105	Onix TCN	Onix TTG
WHITE SILVER Ref.: SX		Onix CLT	Onix TLT	Onix T105	Onix TCN	Onix TTG
WHITE RED Ref.: SY		Onix CLT	Onix TLT	Onix T105	Onix TCN	Onix TTG
WHITE BLUE Ref.: SZ		Onix CLT	Onix TLT	Onix T105	Onix TCN	Onix TTG

# ARGUMENTATION



## 01. PRODUCT ID

NAME	Lobular
USE	Competition/sport
CONSTRUCTION	TIG Welding
MATERIALS	6000 Aluminium. Triple thickness. Dissolution treatment. Orbea Carbon Gold fork
WARRANTY	Lifetime Warranty
DESIGN	Hand-painted in a choice of four colours
TECHNOLOGY	    

## 02. BENEFITS

### Who is the Lobular designed for?

Lobular is designed for aluminium lovers. Great sensations on the road, that feeling of authenticity... people who love to compete, people who realise the importance for their progress of having the right bike. People who know what they want, who love competition, who want the perfect partner for their hobby to help them get the most out of riding, whatever their routes or challenges.

### Recommended by?

It is vouched for by the work of our Engineering, Research and Design Department, and by the Quality Department, which carries out UNE standard testing to certify Orbea's unbeatable characteristics.

### Why Orbea?

Orbea offers you the possibility of designing your own bike. You have a dream and we can make it come true. Orbea offers you two models, four colours, numerous assembly options and you can even customise your bike by putting your name on it. In short, a bike created for you and by you.



### 03. STRONG POINTS

#### Lifetime Warranty



Orbea provides a lifetime guarantee on all its frames. Only a brand that knows the materials, masters the technologies and has the skills can guarantee your frame to be totally reliable. Only Orbea takes you a step beyond.

#### ORBEA DESIGN



Orbea Design is based on what we consider the four essential elements of bicycle design: the riders, the state-of-the-art technology, the creation process and the trends. The logo we have chosen for Orbea Design explains it perfectly: each of these concepts is a key feature of the way we work.

#### My Orbea



Orbea offers you the possibility of designing your own bike. You have a dream and we can make it come true. We're here to help you choose. Orbea offers you options for colour, assembly, size and ergonomics: transmission, handlebar width, crank length, seatpost length... in short, it adapts to you, it's created by you and for you.

#### HAND-PAINTED

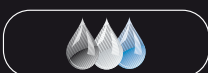

Our painting installations comply with current and future environmental protection legislation, and we use water-based paints, recycling the water used by the system. We are the only European bicycle sector company that uses this painting technology. The quality of our finishes and paintwork is exceptional.







#### ORBEA HYDRO



Hydro enables extremely light frames to be produced with mechanical properties never before achieved. This aluminum incorporating Al, Si and Mg, undergoes double T4 and T6 heat treatment at temperatures up to 535 ° C. It also incorporates the triple-butting feature providing minimum weight with high levels of stiffness and reliability. This is the most unique and appropriate aluminum when extreme performance is required.



### lobular . TLT

-  ORBEA LOBULAR+100% CARBON
-  ORBEA ORCA
-  SHIMANO ULTEGRA
-  MAVIC KSYRIUM EQUIPE
-  48/49/50/51/52/53/54/55/56/57/58/59/60/61/62
-  SILVER GREY







# lobular



What would you think if we presented a bike designed in aluminium, with made-to-measure geometry, sturdy and also rigid and lightweight? Do you think we're joking? We're certainly not! We'd like to present the Lobular. A bike built with 6000 triple thickness aluminium alloy tubes using dissolution heat treatment to create a chassis with just the right lightness-to-stiffness ratio. Created with carbon fibres on the rear triangle to improve bumpy terrain absorption. It also stands out for its manoeuvrability, as we have shortened the crossbar and added a higher head tube. The result isn't a dream, it's the Lobular: a bike that's totally guaranteed, ideal for amateurs who feel like professionals on the road.



### lobular . TCN

-  ORBEA LOBULAR+100% CARBON
-  ORBEA ORCA
-  CAMPAGNOLO CENTAUR
-  MAVIC KSYRIUM EQUIPE
-  48/49/50/51/52/53/54/55/56/57/58/59/60/61/62
-  SILVER RED

## SPECIFICATIONS

lobular 

CHARACTERISTICS	lobular . TLT	lobular . TCN
<b>FRAME</b>	ORBEA LOBULAR+100% CARBON	ORBEA LOBULAR+100% CARBON
<b>FORK</b>	ORBEA ORCA	ORBEA ORCA
<b>CRANKSET</b>	SHIMANO ULTEGRA 34x50 CT	CAMPAGNOLO CENTAUR 34x50 CT
<b>HEADSET</b>	INTEGRATED 1 1/8	INTEGRATED 1 1/8
<b>HANDLEBAR</b>	ORBEA WING ALU	ORBEA WING ALU
<b>STEM</b>	ORBEA CARBON ALU	ORBEA CARBON ALU
<b>SHIFTERS</b>	SHIMANO ULTEGRA	CAMPAGNOLO CENTAUR
<b>BRAKES</b>	SHIMANO ULTEGRA	CAMPAGNOLO CENTAUR
<b>REAR DERAILLEUR</b>	SHIMANO ULTEGRA	CAMPAGNOLO CENTAUR
<b>FRONT DERAILLEUR</b>	SHIMANO ULTEGRA	CAMPAGNOLO CENTAUR
<b>CHAIN</b>	SHIMANO ULTEGRA	KMC DX-10
<b>WHEELS</b>	MAVIC KSYRIUM EQUIPE	MAVIC KSYRIUM EQUIPE
<b>REAR COGS</b>	SHIMANO ULTEGRA 12-25 10S	CAMPAGNOLO CENTAUR 12-25 10S
<b>TYRES</b>	VITTORIA RUBINO PRO 700x23	VITTORIA RUBINO PRO 700x23
<b>PEDALS</b>	LOOK KEO CLASSIC	LOOK KEO CLASSIC
<b>SEAT POST</b>	ORBEA CARBON PRO 2	ORBEA CARBON PRO 2
<b>SADDLE</b>	SELLE ITALIA FLITE GEL FLOW	SELLE ITALIA FLITE GEL FLOW

OPTIONS	lobular . TLT	lobular . TCN
<b>CRANKSET</b>	SHIMANO ULTEGRA 30x39x53 SHIMANO ULTEGRA 39x53	CAMPAGNOLO CENTAUR 39x53 -
<b>WHEELS</b>	MAVIC KSYRIUM ELITE MAVIC KSYRIUM SL	MAVIC KSYRIUM SL MAVIC KSYRIUM ELITE
<b>SADDLE</b>	MAVIC COSMIC CARBON SL SELLE ITALIA SLR XP FLOW	MAVIC COSMIC CARBON SL SELLE ITALIA SLR XP FLOW

## GEOMETRY

lobular 

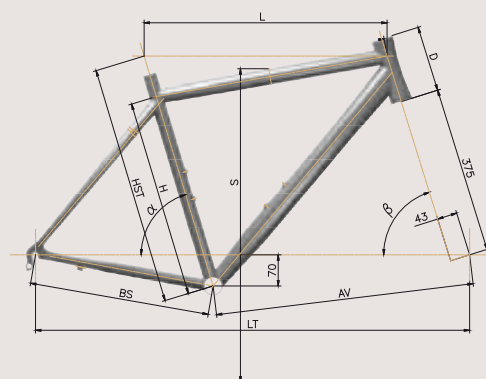

SIZES	HST	H	L	D	BS	AV	LT	S	$\alpha$	$\beta$
48	480	430	520	104	405	575	970	720	74.75°	71.5°
49	490	440	520	111	405	575	970	730	74.6°	71.4°
50	500	450	525	120	405	575	970	740	74°	71.4°
51	510	460	535	120	405	575	970	750	73.5°	72.1°
52	520	470	540	129	405	580	975	755	73.5°	72.1°
53	530	480	545	145	405	585	980	770	73.5°	72.1°
54	540	490	550	155	408	585	983	780	73.2°	72.4°
55	550	500	555	165	408	590	988	785	73.2°	72.4°
56	560	510	560	175	408	595	993	800	73.2°	72.4°
57	570	520	570	185	408	600	998	810	73.2°	72.9°
58	580	530	575	185	408	605	1003	815	73.2°	73°
59	590	540	585	195	408	610	1008	820	73.2°	73.5°
60	600	550	590	205	408	615	1013	835	73.2°	73.5°
61	610	560	595	213	408	615	1013	840	73.2°	74°
62	620	570	600	213	408	615	1013	850	73.2°	74.5°

## COLOURS

lobular 



Lobular TLT  
Lobular TCN



Lobular TLT  
Lobular TCN



Lobular TLT  
Lobular TCN





Lobular TLT  
Lobular TCN

# ARGUMENTATION

## aqua

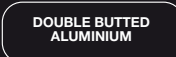
### 01. PRODUCT ID

NAME	Aqua
USE	Leisure sport and initiation
CONSTRUCTION	TIG Welding
MATERIALS	Double thickness 7005 aluminium, T6 heat treatment, Orbea Carbon Bronze monocoque fork
WARRANTY	Lifetime warranty
DESIGN	Hand-painted in a choice of four colours
TECHNOLOGY	  

### 02. BENEFITS

#### Who is the Aqua designed for?

This is a reliable bike, ideal for initiation. It's the perfect companion if you're taking up cycling for the first time, and the perfect partner for riding hundreds of kilometres with no drop in performance or durability.

Aqua is the ideal bike for leisure, for riding your favourite roads and for getting to destinations that other bikes can't take you to. Because to get to the top and enjoy it, you need the right bike and you need it to be reliable.

#### Who rides it?

Richard Poulen, member of the Bordeaux Cycling Club (France)

#### Richard Poulen

(35 years old) France  
Member of the Bordeaux Cycling Club

#### The Quebrantahuesos for the first time?

The first time was six years ago, and I haven't missed a race since. But I didn't start out with the Quebrantahuesos, my first race was the Treparriscos. Phew! And that was a difficult one! I have great memories of it, I've never been so hot in all my life! But I just wanted to finish, and feel part of a race that's so important in Spain, and share my love of the sport with all the other race fans.

#### Which bike did you start out with?

I had a Zeus. A great bike, but I'd been thinking of changing it for a long time, and after that race I went for it. I wanted a bike that suited what I was doing better - I'd had the Zeus for 10 years and I needed a new one. I couldn't afford an Onix, which was my favourite, so I went for an Aqua. The next year I tried it out in the Quebrantahuesos.

#### What does the Aqua do for you?

Everything! It's my escape route. I belong to the Bordeaux Cycling Club in France. We take part in the Quebrantahuesos every year, and in the Octogonal too. And we ride whenever we can. At weekends we get some serious cycling done, at least a hundred kilometres. The Aqua is very safe and reliable and I really like its shape.

#### What's the next step for you?

Winning the Quebrantahuesos... (laughter). No... I just want to go on enjoying racing with an Onix. I'm an aluminium fan, and the Aqua is very smooth, but I wouldn't mind trying a carbon bike. Would Orbea give me a free Onix?



### 03. STRONG POINTS

#### LIFETIME WARRANTY



Orbea provides a lifetime guarantee on all its frames. Only a brand that knows the materials, masters the technologies and has the skills can guarantee your frame to be totally reliable. Only Orbea takes you a step beyond.

#### ORBEA DESIGN



Orbea Design is based on what we consider the four essential elements of bicycle design: the riders, the state-of-the-art technology, the creation process and the trends. The logo we have chosen for Orbea Design explains it perfectly: each of these concepts is a key feature of the way we work.

#### My Orbea



Orbea offers you the possibility of designing your own bike. You have a dream and we can make it come true. We're here to help you choose. Orbea offers you options for colour, assembly, size and ergonomics: transmission, handlebar width, crank length, seatpost length... in short, it adapts to you, it's created by you and for you.

#### HAND-PAINTED

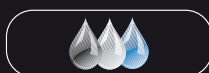

Our painting installations comply with current and future environmental protection legislation, and we use water-based paints, recycling the water used by the system. We are the only European bicycle sector company that uses this painting technology. The quality of our finishes and paintwork is exceptional.

#### ORBEA ALU



The Alu is characterized by extremely light frames with a high strength/weight ratio. Composed of Al, Zn and Mg it receives T6 thermal treatment and double butting obtaining a highly balanced frame. This is high performance for demanding users.





### aqua . TLT

-  ORBEA AQUA
-  ORBEA CARBON
-  SHIMANO ULTEGRA
-  MAVIC RS20
-  48/51/54/57/60
-  WHITE RED

## aqua

Excellent features, an attractive image and affordability for just about anyone. Those are the three mainstays of the Aqua frame: aluminium with excellent features, lightweight and with a great appearance. We've created this great range of bikes with different colours, assemblies and components, knowing that no two tour riders are the same.



### aqua . T105

-  ORBEA AQUA
-  ORBEA CARBON
-  SHIMANO 105
-  SHIMANO WH-R500 BLACK
-  48/51/54/57/60
-  WHITE ORANGE



aqua . TVL

-  ORBEA AQUA  48/51/54/57/60
-  ORBEA CARBON WHITE BLUE
-  CAMPAGNOLO VELOCE
-  CAMPAGNOLO KHAMSIN







aqua . TTG

-  ORBEA AQUA  48/51/54/57/60
-  ORBEA CARBON BLACK WHITE
-  SHIMANO TIAGRA
-  SHIMANO WH-R500 BLACK







aqua . TSR

-  ORBEA AQUA  48/51/54/57/60
-  ORBEA CARBON WHITE BLUE
-  SHIMANO SORA
-  RODI KRONOS SILVER



aqua . T23

-  ORBEA AQUA  48/51/54/57/60
-  ORBEA CARBON WHITE RED
-  SHIMANO 2300
-  RODI KRONOS SILVER



aqua . JUNIOR

-  ORBEA AQUA  47
-  ORBEA CARBON WHITE
-  SHIMANO 2300
-  RODI KRONOS SILVER

## SPECIFICATIONS aqua

CHARACTERISTICS	aqua . TLT	aqua . T105	aqua . TVL	aqua . TTG
FRAME	ORBEA AQUA	ORBEA AQUA	ORBEA AQUA	ORBEA AQUA
FORK	ORBEA CARBON	ORBEA CARBON	ORBEA CARBON	ORBEA CARBON
CRANKSET	SHIMANO ULTEGRA 34x50 CT	SHIMANO 105 34x50 CT	CAMPAGNOLO VELOCE 34x50 CT	SHIMANO TIAGRA 34x50 CT
HEADSET	SEMIINTEGRATED 1 1/8	SEMIINTEGRATED 1 1/8	SEMIINTEGRATED 1 1/8	SEMIINTEGRATED 1 1/8
HANDLEBAR	ORBEA ALU PRO	ORBEA ROAD	ORBEA ROAD	ORBEA ROAD
STEM	ORBEA ALU PRO	ORBEA ALU	ORBEA ALU	ORBEA ALU
SHIFTERS	SHIMANO ULTEGRA	SHIMANO 105	CAMPAGNOLO VELOCE	SHIMANO TIAGRA
BRAKES	SHIMANO ULTEGRA	SHIMANO 105	ORBEA PRO	ORBEA PRO
REAR DERAILLEUR	SHIMANO ULTEGRA	SHIMANO 105	CAMPAGNOLO VELOCE	SHIMANO TIAGRA
FRONT DERAILLEUR	SHIMANO ULTEGRA	SHIMANO 105	CAMPAGNOLO VELOCE	SHIMANO TIAGRA
CHAIN	SHIMANO ULTEGRA	SHIMANO 105	KMC DX-10	SHIMANO HG53
WHEELS	MAVIC RS20	SHIMANO WH-R500 BLACK	CAMPAGNOLO KHAMSIN	SHIMANO WH-R500 BLACK
REAR COGS	SHIMANO ULTEGRA 12-25 10S	SHIMANO 105 12-25 10S	CAMPAGNOLO VELOCE 12-25 10S	SHIMANO TIAGRA 12-25 9S
TYRES	VITTORIA ZAFIRO 700x23	VITTORIA ZAFIRO 700x23	VITTORIA ZAFIRO 700x23	VITTORIA ZAFIRO 700x23
PEDALS	LOOK KEO EASY	LOOK KEO EASY	LOOK KEO EASY	LOOK KEO EASY
SEAT POST	ORBEA CARBON	ORBEA CARBON	ORBEA CARBON	ORBEA CARBON
SADDLE	SELLE ITALIA X2 PRO	SELLE ITALIA X2 PRO	SELLE ITALIA X2 PRO	SELLE ITALIA X2 PRO

OPTIONS	aqua . TLT	aqua . T105	aqua . TVL	aqua . TTG
CRANKSET	SHIMANO ULTEGRA 30x39x52 SHIMANO ULTEGRA 39x53	SHIMANO 105 30x39x50 SHIMANO 105 39x53	CAMPAGNOLO VELOCE 39x53 -	SHIMANO TIAGRA 30x39x50 SHIMANO TIAGRA 39x52
PEDALS	-	-	-	-

## GEOMETRY aqua

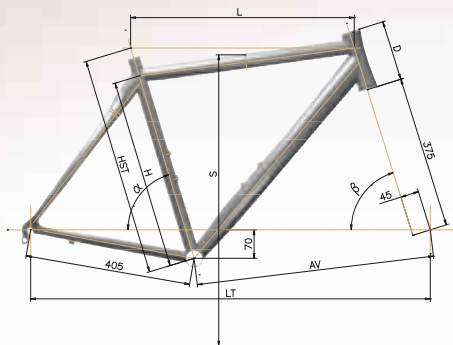

SIZES	HST	H	L	D	AV	LT	S	$\alpha$	$\beta$
47	478	410	504	92	575	966	716	75.2°	70°
48	495	430	520	102	575	970	720	74.75°	71.5°
51	517	460	535	120	575	970	750	73.5°	72.3°
54	547	490	550	148	585	983	780	73.2°	72.6°
57	577	520	570	176	600	998	810	73.2°	73.2°
60	607	550	590	204	615	1013	835	73.2°	73.7°

\*Size 47 only AQUA JUNIOR

# ARGUMENTATION

## aqua

### 01. PRODUCT ID

NAME	Orbea Aqua
USE	Leisure sport and initiation
CONSTRUCTION	TIG Welding
MATERIALS	Double thickness 7005 aluminium, T6 heat treatment, Orbea Carbon Bronze monocoque fork
WARRANTY	Lifetime warranty
DESIGN	Hand-painted in a choice of four colours

#### TECHNOLOGY



### 02. BENEFITS

#### Who is the Aqua designed for?

This is a reliable bike, ideal for initiation. It's the perfect companion if you're taking up cycling for the first time, and the perfect partner for riding hundreds of kilometres with no drop in performance or durability.

Aqua is the ideal bike for leisure, for riding your favourite roads and for getting to destinations that other bikes can't take you to. Because to get to the top and enjoy it, you need the right bike and you need it to be reliable.

### 03. STRONG POINTS

WARRANTY  
ORBEA



ORBEA  
DESIGN



MyO



PINTADO A MANO



#### aqua . TSR

ORBEA AQUA	ORBEA AQUA	ORBEA AQUA
ORBEA CARBON	ORBEA CARBON	ORBEA CARBON
SHIMANO SORA 34x50 CT	SHIMANO 2300 34x50 CT	ORBEA ALU 34x42
SEMIINTEGRATED 1 1/8	SEMIINTEGRATED 1 1/8	SEMIINTEGRATED 1 1/8
ORBEA ROAD	ORBEA ROAD	ORBEA ROAD
ORBEA ALU	ORBEA ALU	ORBEA ALU
SHIMANO SORA	SHIMANO 2300	SHIMANO 2300
ORBEA ALU	ORBEA ALU	ORBEA ALU
SHIMANO SORA	SHIMANO 2300	SHIMANO 2300
SHIMANO SORA	SHIMANO 2300	SHIMANO 2300
SHIMANO HG53	SHIMANO HG50	SHIMANO HG50
ORBEA KRONOS SILVER	ORBEA KRONOS SILVER	ORBEA KRONOS SILVER
SHIMANO TIAGRA 12-25 9S	SHIMANO HG50 13-26 8S	SHIMANO HG50 13-26 8S
VITTORIA ZAFIRO 700x23	VITTORIA ZAFIRO 700x23	VITTORIA ZAFIRO 700x23
ORBEA ROAD ALU	ORBEA ROAD ALU	ORBEA ROAD ALU
ORBEA ALU	ORBEA ALU	-
SELLE ITALIA X2 PRO	SELLE ITALIA X2 PRO	SELLE ITALIA X2 PRO

#### aqua . TSR

SHIMANO SORA 30x39x50	SHIMANO 2300 (30x42x52)	ORBEA ALU 39x46x165 + 16x24
-	-	-
LOOK KEO EASY	LOOK KEO EASY	-

## COLOURS

### aqua

WHITE BLUE  
Ref.: D1



Aqua TLT  
Aqua T105  
Aqua TVL  
Aqua TTG  
Aqua TSR  
Aqua T23  
Aqua JUNIOR

WHITE RED  
Ref.: D2



Aqua TLT  
Aqua T105  
Aqua TVL  
Aqua TTG  
Aqua TSR  
Aqua T23  
Aqua JUNIOR

WHITE ORANGE  
Ref.: D3



Aqua TLT  
Aqua T105  
Aqua TVL  
Aqua TTG  
Aqua TSR  
Aqua T23  
Aqua JUNIOR

BLACK WHITE  
Ref.: D4





Aqua TLT  
Aqua T105  
Aqua TVL  
Aqua TTG  
Aqua TSR  
Aqua T23  
Aqua JUNIOR

# ARGUMENTATION

## Fitness

### 01. PRODUCT ID

NAME	Onix, Aqua
USE	Leisure
CONSTRUCTION	Orbea Monocoque y soldadura TIG
MATERIALS	Orbea Carbon Bronze and Double-thick 7005 aluminum
WARRANTY	Lifetime Warranty
DESIGN	MyOrbea
TECHNOLOGY	 

### 02. BENEFITS

**José Ramiro Sáez (42 years old) Spain, Sales Agent**

#### Why did you choose a Onix?

I like the road, I like cycling, but I'm not a professional. So I need a bike that'll let me see the world around me and enjoy the area I live in.

#### What do the flat handlebars offer?

I'm from Altea near Valencia, and the people here don't know what a perfect day means until they get on a bike like this one and ride off down the coast road. And it's so close – just half an hour's ride and you start to feel the sea breeze and see the beach of El Albir and the little bays along the coast.

#### Are you a roadster?

Of course! I love the road but for me it's a means, not an end. As I said, a ride down the coast road in the morning or when the sun's just going down simply defies description. And with the Diem you're in such a comfortable position, it's like sitting on the sofa but in motion, haha...!

#### Why would you recommend this bike?

I'm no bike expert, I chose this one for its features, because it has a guarantee that saves any trouble, it's really comfortable and its appearance is quite spectacular. When I retire I'll trade my car in and my Diem will be my transport for getting round Altea.

### 03. STRONG POINTS

**onix**

Onix is experience. It's a bike you can use to enjoy the routes that will lead you to health and relaxation. Flat handlebars, relaxed posture, guaranteed enjoyment. Orbea's Carbon Bronze fibres guarantee light weight, durability and performance. It also has an attractive design and first-rate enjoyment value, monocoque construction and SSN. If we go on we'll shame the competition!

**aqua**

You'll be in your element with an Aqua bike. Because this frame's characteristics, top-class features, appealing image and affordable price go hand-in-hand with flat handlebars and an attractive assembly that'll be perfect for going out and enjoying the open air.



### 03. STRONG POINTS

#### onix

##### SSN TECHNOLOGY



Each bike size is designed individually, optimising the frame structure according to the stiffness ratio and the cyclist's body mass. The result is five individually-designed frames, 100% exclusive and perfectly balanced.

##### ORBEA CARBON BRONZE



Orbea Carbon Bronze fibres are intermediate module fibres that seek maximum performance by combining elasticity, durability and creating a frame accessible to anyone.

##### MONOCOQUE TECHNOLOGY



The tension is optimally distributed over the entire structure, there are no seals and no joints, thus minimising critical areas. This means your frame will stand up to the toughest demands, and the structure will not lose any of its characteristics, however much you use it.

#### aqua

##### LIFETIME WARRANTY



Orbea provides a lifetime guarantee on all its frames. Only a brand that knows the materials, masters the technologies and has the skills can guarantee your frame to be totally reliable. Only Orbea takes you a step beyond.

##### ORBEA DESIGN



Orbea Design is based on what we consider the four essential elements of bicycle design: the riders, the state-of-the-art technology, the creation process and the trends. The logo we have chosen for Orbea Design explains it perfectly: each of these concepts is a key feature of the way we work.

##### ORBEA ALU



The Alu is characterized by extremely light frames with a high strength/weight ratio. Composed of Al, Zn and Mg it receives T6 thermal treatment and double butting obtaining a highly balanced frame. This is high performance for demanding users.



**onix . SPATIOS**

-  ORBEA ONIX
-  ORBEA AC
-  SHIMANO 105
-  SHIMANO WH-R500 BLACK
-  48/51/54/57/60
-  WHITE SILVER

# Fitness

You like the landscape, enjoying your surroundings and the environment. We know that, and so we've designed these bicycles with three tried and true frames with a more relaxed riding position. Because you see cycling differently, you prefer a posture that lets you enjoy your surroundings, handlebars you can rest your arms on as you enjoy the views.



**aqua . NEOS**

-  ORBEA AQUA
-  ORBEA CARBON
-  SHIMANO TIAGRA
-  SHIMANO WH-R500 BLACK
-  48/51/54/57/60
-  BLACK WHITE



aqua . BIOS

-  ORBEA AQUA
  -  ORBEA CARBON
  -  SHIMANO SORA
  -  RODI KRONOS SILVER
-  48/51/54/57/60
-  WHITE RED



aqua . AOS

-  ORBEA AQUA
  -  ORBEA CARBON
  -  SHIMANO 2300
  -  ORBEA 28 SILVER
-  48/51/54/57/60
-  WHITE BLUE



## SPECIFICATIONS Fitness

CHARACTERISTICS	<b>ONIX . SPATIOS</b>	<b>aqua . NEOS</b>	<b>aqua . BIOS</b>
<b>FRAME</b>	ORBEA ONIX	ORBEA AQUA	ORBEA AQUA
<b>FORK</b>	ORBEA AC	ORBEA CARBON	ORBEA CARBON
<b>CRANKSET</b>	SHIMANO 105 30x39x50	SHIMANO TIAGRA 30x39x50	SHIMANO SORA 30x39x50
<b>HEADSET</b>	INTEGRATED 1 1/8	SEMIINTEGRATED 1 1/8	SEMIINTEGRATED 1 1/8
<b>HANDLEBAR</b>	ORBEA FLAT ALU	ORBEA FLAT ALU	ORBEA FLAT ALU
<b>STEM</b>	ORBEA ADJUSTABLE	ORBEA ADJUSTABLE	ORBEA ADJUSTABLE
<b>SHIFTERS</b>	SHIMANO R770	SHIMANO R440	SHIMANO R440
<b>BRAKES</b>	SHIMANO 105	ORBEA PRO	ORBEA PRO
<b>REAR DERAILLEUR</b>	SHIMANO 105	SHIMANO TIAGRA	SHIMANO SORA
<b>FRONT DERAILLEUR</b>	SHIMANO R773	SHIMANO TIAGRA	SHIMANO R453
<b>CHAIN</b>	SHIMANO 105	SHIMANO HG53	SHIMANO HG53
<b>WHEELS</b>	SHIMANO WH-R500 BLACK	SHIMANO WH-R500 BLACK	ORBEA KRONOS SILVER
<b>REAR COGS</b>	SHIMANO 105 12-25 10S	SHIMANO TIAGRA 12-25 9S	SHIMANO TIAGRA 12-25 9S
<b>TYRES</b>	VITTORIA RUBINO 700x23	VITTORIA ZAFIRO 700x23	VITTORIA ZAFIRO 700x23
<b>PEDALS</b>	LOOK KEO EASY	LOOK KEO EASY	LOOK KEO EASY
<b>SEAT POST</b>	ORBEA CARBON	ORBEA CARBON	ORBEA CARBON
<b>SADDLE</b>	SELLE ITALIA SL FLOW	SELLE ITALIA X2 PRO	SELLE ITALIA X2 PRO



aqua . AOS

- ORBEA AQUA
- ORBEA CARBON
- FCM 131 28x38x48
- SEMIINTEGRATED 1 1/8
- ORBEA FLAT ALU
- ORBEA ADJUSTABLE
- SHIMANO STEF60
- ORBEA ALU
- SHIMANO 2300
- SHIMANO R453
- SHIMANO HG50
- ORBEA 28 SILVER
- DNP 12-23 8S
- VITTORIA ZAFIRO 700x23
- ORBEA ROAD ALU
- ORBEA ALU
- SELLE ITALIA X2 PRO

GEOMETRY  
Fitness

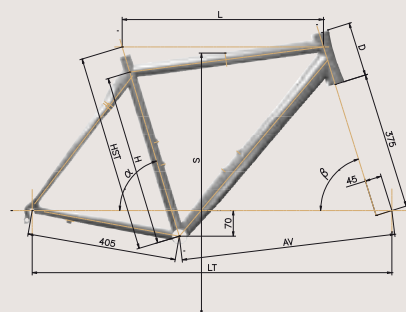
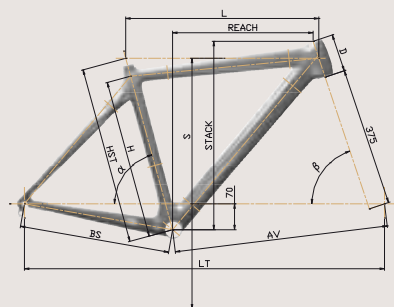

onix

SIZES	HST	H	L	D	BS	AV	LT	S	$\alpha$	$\beta$	Reach	Stack
48	480	430	520	102	405	57	970	720	74.75°	71.5°	360	500
51	510	460	535	122	405	557	970	750	73.5°	72.1°	377	530
54	540	490	550	152	408	558	983	780	73.2°	72.4°	379	559
57	570	520	570	182	408	560	998	810	73.2°	72.9°	391	590
60	600	550	590	212	408	615	1013	835	73.2°	73.5°	403	621

aqua

SIZES	HST	H	L	D	AV	LT	S	$\alpha$	$\beta$
48	495	430	520	102	575	970	720	74.75°	71.5°
51	517	460	535	120	575	970	750	73.5°	72.3°
54	547	490	550	148	585	983	780	73.2°	72.6°
57	577	520	570	176	600	998	810	73.2°	73.2°
60	607	550	590	204	615	1013	835	73.2°	73.7°

COLOURS  
Fitness





CARBON WHITE	WHITE SILVER	WHITE RED	WHITE BLUE
Ref.: SW	Ref.: SX	Ref.: SY	Ref.: SZ
Onix SPATIOS	Onix SPATIOS	Onix SPATIOS	Onix SPATIOS
WHITE BLUE	WHITE RED	WHITE ORANGE	BLACK WHITE
Ref.: D1	Ref.: D2	Ref.: D3	Ref.: D4
Aqua AOS Aqua BIOS Aqua NEOS	Aqua AOS Aqua BIOS Aqua NEOS	Aqua AOS Aqua BIOS Aqua NEOS	Aqua AOS Aqua BIOS Aqua NEOS

# ARGUMENTATION

## Ciclocross



### 01. PRODUCT ID

NAME	Orbea Terra
USE	Silver: Competition Aluminium: Competition - Sports
CONSTRUCTION	Orbea Monocoque, Carbon stops , Single shell, Oversize Headtube, BB30
MATERIALS	Orbea Carbon Silver and Orbea Aluminium.
WARRANTY	Lifetime Warranty
DESIGN	Orbea Design
TECHNOLOGY	   

### 02. BENEFITS

#### What is Terra?

Orbea does not envisage manufacturing bikes for anything other than competition. It's in our blood. We are leaders on the road with Orca and Euskaltel-Euskadi, in triathlon with Ordu and Craig Alexander, in MTB with Alma and Julien Absalon. Terra is our desire to step into the cyclocross world. We have put all our knowledge and technology together to create a light, rigid carbon frame and offer features that make it ideal for putting it to the test at competition level. Want to take it to the top?

#### How does it differ from others?

The ATT Ergonomy System technology. Cyclocross races are plagued with obstacles. With that in mind we have created an assembly with an asymmetric horizontal frame. With this, we create a greater contact area between the cyclist and the bike for those stretches where it has to be carried on the shoulder.

The DCR direct cabling system is another of the advantages that the Orbea Terra offers cyclocross users. The technology created by Orbea and successfully tested in Alma and Orca, has been transferred to Terra to obtain greater precision and gear change smoothness, decreasing friction and maintenance and avoiding dirt getting in, part and parcel of this sport. Additionally this direct cabling is specific to Terra as we have moved it to the right side to optimize comfort and as a consequence the cyclist's performance.

#### Who recommends it?

Its reliability durability and performance are certified by our Engineering, Research and Design Department and guaranteed by the Quality Area with UNE standard tests.

## 03. STRONG POINTS

### SSN TECHNOLOGY



Each bike size is designed individually, optimising the frame structure according to the stiffness ratio and the cyclist's body mass. The result is five individually-designed frames, 100% exclusive and perfectly balanced.

### ATT ERGONOMY SYSTEM



We have created a frame with a horizontal asymmetric tube to offer the maximum contact area to the cyclist. This innovation provides enhanced comfort during sections when the bicycle is carried on the shoulder which takes its toll on the performance of the riders. In addition, moving the cables to the right of the frame leaves the surface completely clear, ideal so as not to cause riders any problems.

### DCR TECHNOLOGY



We have created a unique cable-routing system that very efficiently routes the cable paths to the brakes and gear change and deflector. In addition, we have improved both the rear and front braking system. Using two pieces of cold cast aluminum, the system operation and smoothness is optimum.

### 4PT



With the 4 Points Triangle we have managed to increase to the full the side stiffness of the rear triangle by inserting a new vertex, with which we can increase torsional strength, and transform more efficiently all the energy of each pedal stroke into acceleration. All concentrated in the rear triangle.

### BB30 TECHNOLOGY



The BB30 system means an over-dimensioned pedal bracket which lowers the weight of the same providing enhanced stiffness on the frame. Therefore we have the greatest possible surface to transfer all the pedal power more efficiently.

### OVERSIZE HEADTUBE



The new 1 1/8 and 1 1/2 headset tubes lighten the fork and increase the front stiffness as well as the capacity of reaction.

### ORBEA CARBON SILVER



Carbon Silver consists of high module fibres providing stiffness and vibration absorption for maximum pedalling efficiency, offering you unbeatable performance/comfort for long journeys. It uses a combination of fibres with maximum Young's Modulus and a high vibration absorption capacity. And that means a bike that's as demanding as you are.

### ORBEA ALUMINIUM



The Alu is characterized by extremely light frames with a high strength/weight ratio. Composed of Al, Zn and Mg it receives T6 thermal treatment and double butting obtaining a highly balanced frame. This is high performance for demanding users.

## 04. COMPARATIVE

	Terra Carbon	Lobular Cross	Terra Alu
Silver Carbon Fiber	●		
Hydro		●	
Aluminium			●
SSN Technology	●		
DCR	●		
ATT Ergonomy System	●		
4PT	●		
Orbea Design	●	●	●
Carbon frame and fork dropouts	●		
Customized aluminum parts	●		
Oversize Headtube	●		
BB30	●		
Customized Geometry		●	



### TERRA Carbon . TDR

	ORBEA TERRA CARBON
	ORBEA TERRA CARBON
	SHIMANO DURA ACE
	SRAM ZIPP 303 CYCLO CROSS
	48/51/54/57/60
	WHITE CARBON RED

# Ciclocross



## TERRA SILVER

We have created the perfect weapon for cyclocross. Frame created in Silver carbon: light, rigid, totally reliable. We incorporate DCR: smoother change, less friction; no more problems with the mud. We innovate. We have moved all the cabling of the horizontal tube to the right part so you can easily carry it on your shoulder, this is ATT Ergonomy System technology. Welcome to the race where the mud fears Terra.

## lobular CROSS

Few people know the satisfaction of finishing caked in mud from head to toe after participating in a cyclocross race. If you have cyclocross

in your blood, you must own a highly versatile bike at an irresistible price. The possibility of creating your geometry to size and the solidness of the Hydro material are two weighty arguments to make a go for it.

## TERRA A

The Terra A frame will enable you start up the sport of cyclocross with a frame with all the guarantees. The double-thickness aluminum offers good stiffness and optimal lightness so that you only have to worry about the mud. This bicycle is aimed at riders, who know what they want, who love the competition, who want a good companion for their sport to make the most of outings, routes and challenges.





**TERRA Carbon . TLT**

 ORBEA TERRA CARBON	 48/51/54/57/60
 ORBEA TERRA CARBON	CARBON SILVER WHITE
 SHIMANO ULTEGRA	
 MAVIC KSYRIUM EQUIPE	



**TERRA Carbon . T105**

 ORBEA TERRA CARBON	 48/51/54/57/60
 ORBEA TERRA CARBON	WHITE CARBON RED
 SHIMANO 105	
 MAVIC AKSIUM BLACK	





**lobular Cross . TLT**

 ORBEA CROSS LOBULAR	 48/51/54/57/60
 CROSS CARBON AC	BLACK SILVER
 SHIMANO ULTEGRA	
 MAVIC AKSIUM BLACK	



**TERRA Alu . TTG**













 ORBEA TERRA ALU	 48/51/54/57/60
 CROSS CARBON AC	WHITE BLACK RED
 SHIMANO TIAGRA	
 SHIMANO WH-R500 BLACK	

## SPECIFICATIONS Ciclocross

CHARACTERISTICS	<b>TERRA Carbon . TDR</b>	<b>TERRA Carbon . TLT</b>	<b>TERRA Carbon . T105</b>
<b>FRAME</b>	ORBEA TERRA CARBON	ORBEA TERRA CARBON	ORBEA TERRA CARBON
<b>FORK</b>	ORBEA TERRA CARBON	ORBEA TERRA CARBON	ORBEA TERRA CARBON
<b>CRANKSET</b>	FSA SLK 46x36	FSA SLK 46x36	FSA GOSSAMER 46x36
<b>HEADSET</b>	SEMIINTEGRATED 1 1/8	SEMIINTEGRATED 1 1/8	SEMIINTEGRATED 1 1/8
<b>HANDLEBAR</b>	ORBEA WING ALU	ORBEA WING ALU	ORBEA ALU PRO
<b>STEM</b>	ORBEA CARBON PRO	ORBEA CARBON ALU	ORBEA ALU PRO
<b>SHIFTERS</b>	SHIMANO DURA ACE	SHIMANO ULTEGRA	SHIMANO 105
<b>BRAKES</b>	TEKTRO SLK	TEKTRO SLK	CROSS ALU
<b>REAR DERAILLEUR</b>	SHIMANO DURA ACE	SHIMANO ULTEGRA	SHIMANO 105
<b>FRONT DERAILLEUR</b>	SHIMANO DURA ACE	SHIMANO ULTEGRA	SHIMANO 105
<b>CHAIN</b>	SHIMANO DURA ACE	SHIMANO ULTEGRA	SHIMANO 105
<b>WHEELS</b>	SRAM ZIPP 303 CYCLO CROSS	MAVIC KSYRIUM EQUIPE	MAVIC AKSIUM BLACK
<b>REAR COGS</b>	SHIMANO DURA ACE 12-25 10S	SHIMANO ULTEGRA 12-25 10S	SHIMANO 105 12-25 10S
<b>TYRES</b>	VITTORIA CROSS XG PRO 700x32	VITTORIA CROSS XG PRO 700x32	VITTORIA CROSS XG PRO 700x32
<b>PEDALS</b>	SHIMANO PDM 520	SHIMANO PDM 520	SHIMANO PDM 520
<b>SEAT POST</b>	ORBEA CARBON PRO 2	ORBEA CARBON PRO 2	ORBEA CARBON PRO 2
<b>SADDLE</b>	SELLE ITALIA SLR XP FLOW	SELLE ITALIA SL FLOW	SELLE ITALIA SL FLOW

OPTIONS	<b>TERRA Carbon . TDR</b>	<b>TERRA Carbon . TLT</b>	<b>TERRA Carbon . T105</b>
<b>CRANKSET</b>	-	ORBEA CARBON PRO	ORBEA CARBON ALU
	MAVIC KSYRIUM EQUIPE	ZIPP 303	MAVIC KSYRIUM ELITE
<b>PEDALS</b>	MAVIC KSYRIUM ELITE	MAVIC KSYRIUM ELITE	MAVIC KSYRIUM EQUIPE
	-	SELLE ITALIA SLR	-

## COLOURS Ciclocross

WHITE CARBON RED	CARBON SILVER WHITE	WHITE BLACK RED	BLACK SILVER WHITE	WHITE BLACK	BLACK SILVER
					
Ref.: IR	Ref.: IS	Ref.: IU	Ref.: IX	Ref.: IL	Ref.: IM
					
Terra C. TDR Terra C. TLT Terra C. T105	Terra C. TDR Terra C. TLT Terra C. T105	Lobular Cross TLT	Lobular Cross TLT	Terra Alu TTG	Terra Alu TTG

## GEOMETRY Ciclocross

### lobular Cross . TLT

ORBEA CROSS LOBULAR	ORBEA TERRA ALU
CROSS CARBON AC	CROSS CARBON AC
FSA GOSSAMER 46x36	FSA GOSSAMER 46x36
INTEGRATED 1 1/8	SEMIINTEGRATED 1 1/8
ORBEA WING ALU	ORBEA ROAD
ORBEA CARBON ALU	ORBEA ALU
SHIMANO ULTEGRA	SHIMANO TIAGRA
CROSS ALU	CROSS ALU
SHIMANO ULTEGRA	SHIMANO TIAGRA
SHIMANO ULTEGRA	SHIMANO TIAGRA
SHIMANO ULTEGRA	SHIMANO HG53
MAVIC AKSIUM BLACK	SHIMANO WH-R500 BLACK
SHIMANO 105 12-25 10S	SHIMANO TIAGRA 12-25 9S
VITTORIA CROSS XG PRO 700x32	VITTORIA CROSS XG PRO 700x32
SHIMANO PDM 520	SHIMANO PDM 520
ORBEA CARBON PRO 2	ORBEA CARBON
SELLE ITALIA X2 LADY	SELLE ITALIA X2 PRO

### TERRA Alu . TTG

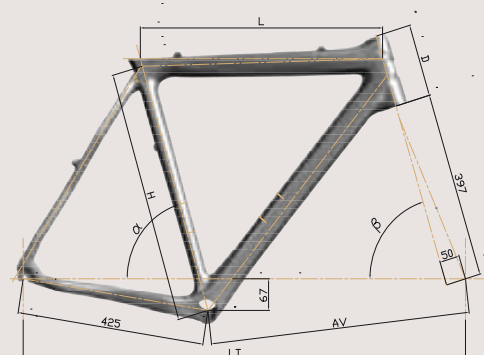

#### TERRA CARBON

SIZES	H	L	D	AV	LT	$\alpha$	$\beta$
48	480	530	107	585	1002	74°	71.8°
51	510	540	132	590	1007	74°	72.5°
54	540	550	158	595	1012	74°	73.1°
57	570	570	188	605	1021	74°	74.2°
60	600	585	208	615	1031	74°	74.7°

### lobular Cross . TLT

-	-
-	-
-	-
-	-

### TERRA Alu . TTG

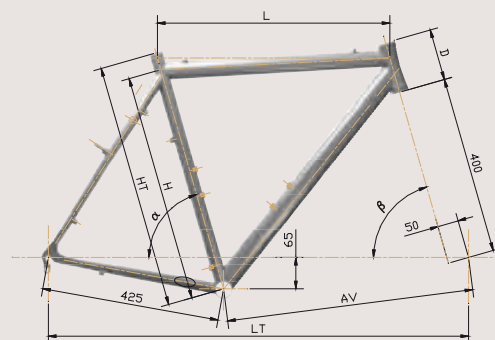

#### LOBULAR CROSS / TERRA ALU

SIZES	H	HT	L	D	AV	LT	$\alpha$	$\beta$
48	480	520	530	104	585	1002	74°	71.8°
51	510	550	540	129	590	1007	74°	72.5°
54	540	580	550	155	595	1012	74°	73.1°
57	570	610	570	185	605	1021	74°	74.2°
60	600	640	585	205	615	1031	74°	74.7°







**ORDU IS  
AERODYNAMICS  
TAKEN  
TO EXTREMES,  
WITH OPTIMUM  
STIFFNESS**

# **TRIATHLON**

Ordu is the bike Eolo, the god of the winds, rides when he wants to outdo the competition. It's a bike created using state-of-the-art technology, optimised to the full in the San Diego wind tunnel and designed for elite athletes. It's a star for competition and professional use, as there is no faster bike on earth when it comes to reaching the finishing line. Competition lovers know that winning a triathlon or time trial is a question of seconds... and those seconds are just what the Ordu gives you.

# ARGUMENTATION



## 01. PRODUCT ID

NAME	Orbea Ordu
USE	Gold: Competition Silver: Competition - Sports
CONSTRUCTION	Orbea Monocoque
MATERIALS	Orbea Carbon Gold and Silver
WARRANTY	Lifetime Warranty
DESIGN	Application of AIZonE project, hand-painted, integrated part design: internal cable guides, clamp

### TECHNOLOGY



74° - 80°  
SEAT-ANGLE

100% INTERNAL  
CABLE

## 02. BENEFITS

### Why Ordu?

We continue moving forward to achieve the best results in the competition and increased user satisfaction. Orbea launches two levels of carbon in the fastest time trial bikes: Gold and Silver. While the first level is designed for top competition, the second is for those who want to make the first step into the world of triple discipline, both are created based on the latest technology optimized to the maximum in the wind tunnel in San Diego.

Designed for competition and professional use, because there is a faster bike to reach the finishing line. Fans of the competition know that victory in a triathlon or a time trial depends on a few seconds ... those Ordu will give you.

### Why is it the fastest?

More aerodynamics does not mean fastest. If this were so we would be making paper thin frames, the problem is that they would not stand up to the great power of our riders. For that reason and because we are one step ahead, we have created the Ordu.

The search for better aerodynamics has a negative effect on the stiffness, which takes away capacity in the transmission of power. Similarly, building a frame with maximum stiffness penalizes aerodynamics. The conclusion is that we must find a balance. This is where we find Ordu. The development criterion of our bike has been to optimize stiffness and minimize the impact of the bicycle on cutting through the air.

Optimum stiffness: The power generated by the cyclist is optimally transferred to the development or slide of the rider.

Perfect drag coefficient: The impact of the bike cutting through the air is the most balanced on the market.

- We use the knowledge we generated in the Wind Tunnel in San Diego as part of the AIZonE Project, to bring you the best bikes you can find.

### Who uses it?

Euskaltel Euskadi: Team UCI PRO TOUR.  
Craig Alexander, 2008 and 2009 Hawaii Ironman Champion triathlete.  
Hunter Kemper, Olympic triathlete in 2000, 2004 and 2008.  
Jarrod Shoemaker, Olympic triathlete in 2004 and 2008.  
Laura Bennett, Silver medal triathlete in the 2003 World Championships and bronze in 2004, 2005 and 2007.  
Marina Damlaimcourt, Spanish Triathlon Champion in 2008.

### Recommended by?

The world's fastest bicycle is vouched for by the knowledge of the Engineering Department at Orbea which has developed the Orbea Ordu at the Mecca for speed: The San Diego Wind Tunnel. It has also been in accordance with UNE standard at our Quality Department.

The results speak for themselves: time trials won by Samuel Sánchez and the Euskaltel-Euskadi team, as well as international trophies won by our triathletes are its best testimonial.

### Why Orbea?

Orbea offers the possibility of designing your own bike. Your wish is our command. Orbea can put two levels of carbon into your hands, in addition to new colors, numerous assembly options and you can even customize it with your name. In short, created for you and by you.

### 03. STRONG POINTS

#### SSN TECHNOLOGY



Each bike size is designed individually, optimising the frame structure according to the stiffness ratio and the cyclist's body mass. The result is five individually-designed frames, 100% exclusive and perfectly balanced.

#### ORBEA CARBON GSB



Orbea masters knowledge on design and construction of carbon bikes to perfection. Our wide experience accumulated in this material has led us to create bikes that meet the needs of the most demanding two-wheel users in the world.

#### MONOCOQUE TECHNOLOGY



The tension is optimally distributed over the entire structure, there are no seals and no joints, thus minimising critical areas. This means your frame will stand up to the toughest demands, and the structure will not lose any of its characteristics, however much you use it.

#### ORBEA DESIGN



Orbea Design is based on what we consider the four essential elements of bicycle design: the riders, the state-of-the-art technology, the creation process and the trends. The logo we have chosen for Orbea Design explains it perfectly: each of these concepts is a key feature of the way we work.

#### ORDU GEOMETRY



Orbea has created a solution providing the maximum possible wheel coverage, taking into account a co-linear geometry with the bottom bracket. The key to this creation is that any cyclist, whatever their size, will be able to assume the right posture on their bicycle.

#### AIzonE BY ORBEA



Creamos conocimiento a través del Túnel del Viento para trasladarlo a nuestras bicicletas. Todo el conocimiento creado a través del proyecto AIzonE se traslada a las fases de concepción de cualquier nueva bicicleta Orbea. Continuación de un proyecto de largo recorrido donde nacerán las sucesivas evoluciones de la Orbea Ordu. Trabajo conjunto con el equipo Euskaitel-Euskadi en las posiciones de sus corredores con el objetivo de mejorar en las pruebas de crono.

#### 74°-80° SEAT-ANGLE

The Ordu frame allows for an angulation range of 74° - 80°. To achieve this, two seatposts are used to cover the 74°-76° and 78°-80° angulations. This gives a clear advantage over other systems:

- it provides a wider range of riding positions, and the rider can adapt their position and obtain more efficient pedalling.

- the 74°-76° angle enables a pedalling position similar to that of a traditional road bike. This is normally recommended for mixed or uphill riding.

- the 78°-80° angle enables a more forward-leaning pedalling position, which is particularly advantageous on flat land as it means greater pedalling power.







### 04. COMPARATIVE



	Gold Carbon Fiber	Silver Carbon Fiber
Gold Carbon Fiber	•	
Silver Carbon Fiber		•
AIzonE	•	•
SSN Technology	•	•
Monocoque	•	•
Punteras aluminio 7000	•	•
Ordu Geometry	•	•
74°-80° seat-angle	•	•
Orbea Design	•	•



 . GDR

-  ORBEA ORDU
-  CRONO CARBON SL
-  SHIMANO DURA ACE
-  ZIPP 808 CLINCHER
-  48/51/54/57
-  CARBON









**Ordu Gold**

Orbea is competition and Ordu is one of our flag bearers. It is the bicycle with which the triathlete Craig Alexander has won on two occasions in the Ironman of Hawaii and it is the weapon of Euskaltel-Euskadi in the time trial stages. Its perfect aerodynamics thanks to the work carried out in the Wind Tunnel of San Diego, its great combination of lightness and stiffness as well as its superb power transmission makes it the fastest bike in the time trials.









 . GDi2

-  ORBEA ORDU GOLD Di2  48/51/54/57
-  CRONO CARBON SL  WHITE
-  SHIMANO DURA ACE Di2
-  ZIPP 808 CLINCHER



 . GLT

-  ORBEA ORDU  48/51/54/57
-  CRONO CARBON SL  CARBON
-  SHIMANO ULTEGRA
-  ZIPP 404 CLINCHER

## SPECIFICATIONS

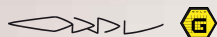

CHARACTERISTICS	. GDR	. GDi2	. GLT
<b>FRAME</b>	ORBEA ORDU	ORBEA ORDU GOLD Di2	ORBEA ORDU
<b>FORK</b>	CRONO CARBON SL	CRONO CARBON SL	CRONO CARBON SL
<b>CRANKSET</b>	SHIMANO DURA ACE 39x53	SHIMANO DURA ACE 39x53	SHIMANO ULTEGRA 39x53
<b>HEADSET</b>	INTEGRATED 1 1/8	INTEGRATED 1 1/8	INTEGRATED 1 1/8
<b>HANDLEBAR</b>	TT ZIPP VUKA AEROBAR	TT PROFILE DESIGN PROSVET	TT PROFILE DESIGN PROSVET
<b>STEM</b>	ORBEA CARBON PRO	ORBEA CARBON PRO	ORBEA CARBON PRO
<b>SHIFTERS</b>	SHIMANO CRONO SLB579H	SHIMANO CRONO Di2	SHIMANO CRONO SLB579H
<b>BRAKES</b>	SHIMANO DURA ACE	SHIMANO DURA ACE	SHIMANO ULTEGRA
<b>REAR DERAILEUR</b>	SHIMANO DURA ACE	SHIMANO DURA ACE Di2	SHIMANO ULTEGRA
<b>FRONT DERAILEUR</b>	SHIMANO DURA ACE	SHIMANO DURA ACE Di2	SHIMANO ULTEGRA
<b>CHAIN</b>	SHIMANO DURA ACE	SHIMANO DURA ACE	SHIMANO ULTEGRA
<b>WHEELS</b>	ZIPP 808 CLINCHER	ZIPP 808 CLINCHER	ZIPP 404 CLINCHER
<b>REAR COGS</b>	SHIMANO DURA ACE 12-25 10S	SHIMANO DURA ACE 12-25 10S	SHIMANO ULTEGRA 12-25 10S
<b>TYRES</b>	MICHELIN PRO3 RACE 700x23	MICHELIN PRO3 RACE 700x23	MICHELIN PRO3 RACE 700x23
<b>PEDALS</b>	LOOK KEO CARBON	LOOK KEO CARBON	LOOK KEO CARBON
<b>SEAT POST</b>	ORBEA ORDU	ORBEA ORDU	ORBEA ORDU
<b>SADDLE</b>	SELLE ITALIA SLRT1	SELLE ITALIA SLRT1	SELLE ITALIA SLRT1

OPTIONS	. GDR	. GDi2	. GLT
<b>HANDLEBAR</b>	ZIPP VUKA BAR+CLIP	-	-
<b>WHEELS</b>	-	ZIPP 404	-
	ZIPP 404	-	MAVIC COSMIC CARBON SL

## ARGUMENTATION



### 01. PRODUCT ID

<b>NAME</b>	Orbea Ordu
<b>USE</b>	Competition
<b>CONSTRUCTION</b>	Orbea Monocoque
<b>MATERIALS</b>	Orbea Carbon Gold, Aluminum Dropouts 7000
<b>WARRANTY</b>	Lifetime Warranty
<b>DESIGN</b>	Application of AIZonE project, hand-painted, integrated part design: internal cable guides, clamp

#### TECHNOLOGY

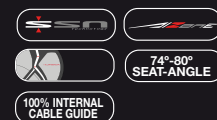

### 02. COMPARATIVE

	ORDU GOLD	ORDU SILVER
Gold	•	
Silver		•
AIZonE	•	•
SSN	•	•
Monocoque	•	•
Aluminum Dropouts	•	•
Ordu Geometry	•	•
74°-80° Angle	•	•
Orbea Design	•	•

## GEOMETRY

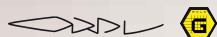

SIZES	H	L	D	AV	LT	β	Reach	Stack
48	530	513	90	575	948	70.5°	375	497
51	553	533	95	579	951	73°	395	512
54	580	549	104	595	968	73°	409	520
57	602	565	111	602	975	74°	422	530

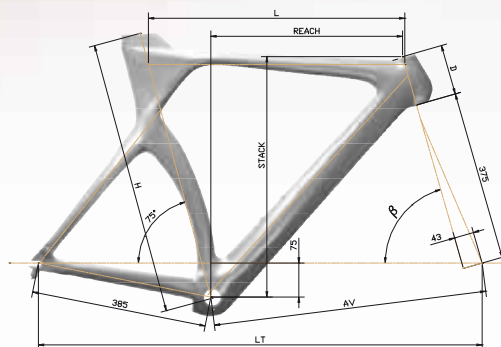

## COLOURS

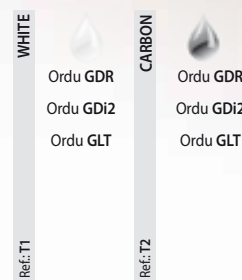



 . SLT

-  ORBEA ORDU SILVER
-  ORBEA ORDU SILVER
-  SHIMANO ULTEGRA
-  MAVIC COSMIC CARBON
-  48/51/54/57
-  SILVER WHITE





**Ordu Silver**

Asphalt, water, wind. The danger of triathlons is that you get hooked. Ride Run Swim Ordu is the perfect weapon if what you want it to excel and win. Trainers. Barefooted. Stopwatch position. It's not easy, but perseverance and passion will make you a winner. Sweat. Breathing. Muscles under strain. The latest technology in aerodynamics with which you will cut through the wind like a knife. Seconds. Minutes. Ordu.



 . S105

-  ORBEA ORDU SILVER
-  ORBEA ORDU SILVER
-  SHIMANO 105
-  MAVIC COSMIC ELITE
-  48/51/54/57
-  WHITE RED

## SPECIFICATIONS



CHARACTERISTICS	. SLT	. S105
FRAME	ORBEA ORDU SILVER	ORBEA ORDU SILVER
FORK	ORBEA ORDU SILVER	ORBEA ORDU SILVER
CRANKSET	SHIMANO ULTEGRA 39x53	SHIMANO 105 39x53
HEADSET	INTEGRATED 1 1/8	INTEGRATED 1 1/8
HANDLEBAR	TT PROFILE DESIGN PROSVET	TT PROFILE DESIGN OZERO
STEM	ORBEA CARBON ALU	ORBEA CARBON ALU
SHIFTERS	SHIMANO CRONO SLB579H	SHIMANO CRONO SLB579H
BRAKES	SHIMANO ULTEGRA	SHIMANO 105
REAR DERAILLEUR	SHIMANO ULTEGRA	SHIMANO 105
FRONT DERAILLEUR	SHIMANO ULTEGRA	SHIMANO 105
CHAIN	SHIMANO ULTEGRA	SHIMANO 105
WHEELS	MAVIC COSMIC CARBON	MAVIC COSMIC ELITE
REAR COGS	SHIMANO ULTEGRA 12-25 10S	SHIMANO 105 12-25 10S
TYRES	VITTORIA RUBINO PRO 700x23	VITTORIA RUBINO PRO 700x23
PEDALS	LOOK KEO CLASSIC	LOOK KEO EASY
SEAT POST	ORBEA ORDU	ORBEA ORDU
SADDLE	SELLE ITALIA SL T1	SELLE ITALIA SL T1

OPTIONS	. SLT	. S105
HANDLEBAR	DROP BAR+SELLE ITALIA SL	DROP BAR+SELLE ITALIA SL
WHEELS	-	ZIPP 404
	ZIPP 404	MAVIC COSMIC CARBON SL

## GEOMETRY

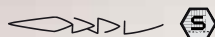

SIZES	H	L	D	AV	LT	$\beta$	Reach	Stack
48	530	513	90	575	948	70.5°	375	497
51	553	533	95	579	951	73°	395	512
54	580	549	104	595	968	73°	409	520
57	602	565	111	602	975	74°	422	530

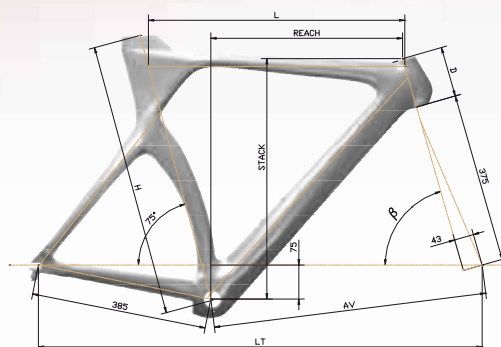

## ARGUMENTATION



### 01. PRODUCT ID

NAME	Orbea Ordu
USE	Competition - Sports
CONSTRUCTION	Orbea Monocoque
MATERIALS	Orbea Carbon Silver, Aluminum Dropouts 7000
WARRANTY	Lifetime Warranty
DESIGN	Application of AIZonE project, hand-painted, integrated part design: internal cable guides, clamp

### TECHNOLOGY

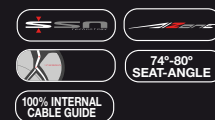

### 02. STRONG POINTS

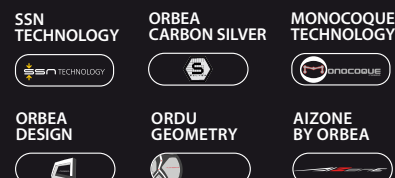

## COLOURS

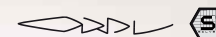

WHITE RED Ref.: 1U		Ordu SLT
		Ordu S105
SILVER WHITE Ref.: 2U		Ordu SLT
		Ordu S105





**YOU'RE DIFFERENT,  
WHY DENY IT?:  
YOU LIVE  
LIFE DIFFERENTLY.**



**DAMA ROAD - ONIX - AQUA - DAMA MOUNTAIN - OCCAM ALU - ALMA - SPORT**

You make a splash of colour wherever you go, and that's important to Orbea. We don't manufacture and assemble bicycles, we devise, design and create solutions for bike lovers. And if our ladies' range is called Dama it's not just because it sounds good: it's because there's a reason behind it. Women are built differently, which is why the geometry of your bike frame needs to be different. The components, the choice of materials and the way we work have all been changed so that whatever your size, the bike will adapt to you, and not the other way round. Welcome to the world of Dama!

# ARGUMENTATION DAMA

## onix aqua

## 01. PRODUCT ID

NAME	Onix Dama and Aqua Dama
USE	Road (leisure sport and competition) and triathlon
CONSTRUCTION	Orbea Monocoque and TIG welding
MATERIALS	Onix Dama frame: Orbea Carbon Bronze Aqua Dama Frame: Double thickness 7005 aluminium, T6 heat treatment, Orbea Carbon Bronze fork
WARRANTY	Lifetime warranty
DESIGN	Hand-painted in a wide choice of colours
TECHNOLOGY	



## 02. BENEFITS

**Marina Damlaimcourt (29), Spain.**  
**Spanish Triathlon Champion**

### What do you think of the Orbea Dama range?

Orbea designs its bikes with women in mind. And it was about time someone did! For competition riding, I need my bike to become part of me, and that's what happens with the Diva. And if that's the case for me - someone with just about the highest demands that exist, you could say - I think all other women will certainly find their perfect geometry in an Orbea bike.

### You race with a Diva. What would you highlight about it?

I'm a triathlete with a specific build, and as the frame is proportional to my height it gives me the comfort a 'standard' frame can't give me. What I most appreciate about the DIVA is that its size fits me perfectly. There are other girls with a similar height to me - between

1.55 and 1.65 metres - and I see them riding bikes that are out of proportion, with a small frame and big wheels. But that's not the case with my DIVA. On other bikes you either have to ride in a stretched-out position or the wheel hits you on the foot. With my height I have no problem. Also, the Diva comes with special girls' handlebars, which make braking easier for women with small hands, for example, which is my case. And it's the same for everything: the gears, the cranks...

### What's the Diva like to race on?

It's a very comfortable bike. As it's carbon, it absorbs the potholes in the road really well. That's a big difference with respect to other aluminium bikes. I really like it. Our races are relatively short, around 40 kilometres, and we tend to ride in a group quite a lot, so you often risk it all with a breakaway, you ride a lot of roundabouts, etc... and thanks to this bike I do very well in those aspects. I feel really safe on it, and it also gives me a good start-off speed".



### 03. STRONG POINTS

#### ONIX

The first level in Orbea carbon bikes is a real experience gatherer. It's a bike with a total guarantee, designed for people who love the open road. Because you're mad about cycling, you like getting the race going, and you love riding with your friends. And you know that to do all that you need a reliable bike, to really make the most of your rides.

#### SSN TECHNOLOGY



#### WARRANTY ORBEA



#### ORBEA DESIGN



#### My Orbea



#### HAND-PAINTED

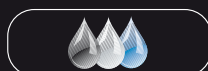

#### ORBEA CARBON BRONZE



#### ORBEA TECH ALU



#### aqua

This is a reliable bike range, ideal for everybody from the beginner to the competitor. It's the perfect companion if you're taking up cycling for the first time, and the perfect partner for riding hundreds of kilometres with no drop in performance or durability. Because if you're going to get to the top and really enjoy it, you need the right bike and you need it to be reliable.

#### WARRANTY ORBEA



#### ORBEA DESIGN



#### ORBEA TECH ALU



#### My Orbea





#### HAND-PAINTED





**ORBEA** DAMA . TLT







-  ORBEA ONIX DAMA
-  ORBEA AC
-  SHIMANO ULTEGRA
-  MAVIC RS20
-  46/49/53
-  WHITE CARBON TURQUOISE

**ORBEA** DAMA

This is the Orbea sportive bike with the spirit of competition and a thirst for the open road. It also has a great appearance and the perfect mix of lightness and stiffness, thanks to the use of Bronze fibres, top-class features and specific women's bike geometry. This is a real long-distance bike for sportive riders that'll keep on going, wherever you're heading for.









**ORBEA** DAMA . T105

-  ORBEA ONIX DAMA
-  ORBEA AC
-  SHIMANO 105
-  MAVIC AKSIUM BLACK
-  46/49/53
-  WHITE PINK



**ORBEA** DAMA . TTG

-  ORBEA ONIX DAMA
-  ORBEA AC
-  SHIMANO TIAGRA
-  SHIMANO WH-R500 BLACK
-  46/49/53
-  WHITE CARBON TURQUOISE

## SPECIFICATIONS

CHARACTERISTICS	ONIX DAMA . TLT	ONIX DAMA . T105	ONIX DAMA . TTG
<b>FRAME</b>	ORBEA ONIX DAMA	ORBEA ONIX DAMA	ORBEA ONIX DAMA
<b>FORK</b>	ORBEA AC	ORBEA AC	ORBEA AC
<b>CRANKSET</b>	SHIMANO ULTEGRA 34x50 CT	SHIMANO 105 34x50 CT	SHIMANO TIAGRA 34x50 CT
<b>HEADSET</b>	INTEGRATED 1 1/8	INTEGRATED 1 1/8	INTEGRATED 1 1/8
<b>HANDLEBAR</b>	ORBEA ALU PRO	ORBEA ALU PRO	ORBEA ALU PRO
<b>STEM</b>	ORBEA ALU PRO	ORBEA ALU PRO	ORBEA ALU PRO
<b>SHIFTERS</b>	SHIMANO ULTEGRA	SHIMANO 105	SHIMANO TIAGRA
<b>BRAKES</b>	SHIMANO ULTEGRA	SHIMANO 105	ORBEA PRO
<b>REAR DERAILLEUR</b>	SHIMANO ULTEGRA	SHIMANO 105	SHIMANO TIAGRA
<b>FRONT DERAILLEUR</b>	SHIMANO ULTEGRA	SHIMANO 105	SHIMANO TIAGRA
<b>CHAIN</b>	SHIMANO ULTEGRA	SHIMANO 105	SHIMANO HG53
<b>WHEELS</b>	MAVIC RS20	MAVIC AKSIUM BLACK	SHIMANO WH-R500 BLACK
<b>REAR COGS</b>	SHIMANO ULTEGRA 12-25 10S	SHIMANO 105 12-25 10S	SHIMANO TIAGRA 12-25 9S
<b>TYRES</b>	VITTORIA RUBINO 700x23	VITTORIA ZAFIRO 700x23	VITTORIA ZAFIRO 700x23
<b>PEDALS</b>	LOOK KEO EASY	LOOK KEO EASY	LOOK KEO EASY
<b>SEAT POST</b>	ORBEA CARBON	ORBEA CARBON	ORBEA CARBON
<b>SADDLE</b>	SELLE ITALIA SL FLOW	SELLE ITALIA SL FLOW	SELLE ITALIA SL FLOW

OPTIONS	ONIX DAMA . TLT	ONIX DAMA . T105	ONIX DAMA . TTG
<b>FORK</b>	ORBEA ORCA	ORBEA ORCA	ORBEA ORCA
<b>CRANKSET</b>	SHIMANO ULTEGRA 30x39x53 SHIMANO ULTEGRA 39x53	SHIMANO 105 30x39x50 SHIMANO 105 39x53	SHIMANO TIAGRA 30x39x50 SHIMANO TIAGRA 39x52
<b>HANDLEBAR</b>	ORBEA WING ALU ORBEA FLAT OC-I + TRIP	ORBEA WING ALU ORBEA FLAT OC-I + TRIP	ORBEA WING ALU FLAT ORBEA OC-I + TRIP
<b>STEM</b>	ORBEA CARBON ALU	ORBEA CARBON ALU	ORBEA CARBON ALU
<b>WHEELS</b>	MAVIC KSYRIUM EQUIPE -	MAVIC KSYRIUM EQUIPE -	MAVIC KSYRIUM EQUIPE MAVIC AKSIUM RACE
<b>PEDALS</b>	-	-	-

## GEOMETRY

ONIX DAMA

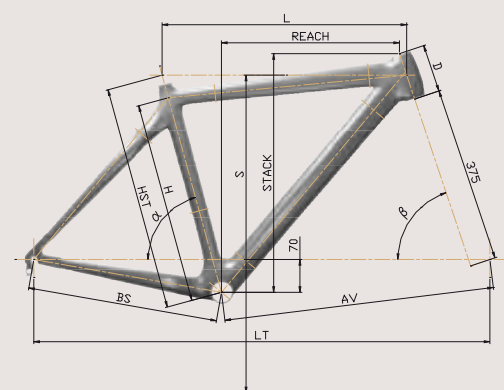

ONIX Dama

SIZES	HST	H	L	D	BS	AV	LT	S	α	β	Reach	Stack
46	450	400	502	105	375	555	924	705	74°	71.5°	365	469
49	490	430	510	110	405	575	970	742	74.5°	70.1°	368	509
53	530	460	525	140	405	575	970	776	74.5°	72°	371	544

\*Size 46 available only in 650 wheels

## COLOURS

ONIX DAMA

WHITE CARBON  
TURQUOISE

Ref.: RS



Onix TLT

Onix T105

Onix TTG

WHITE CARBON  
PINK

Ref.: RT



Onix TLT





Onix T105

Onix TTG





### aqua DAMA . TTG

-  ORBEA AQUA DAMA
-  ORBEA CARBON
-  SHIMANO TIAGRA
-  SHIMANO WH-R500 BLACK
-  47/49/53/56
-  WHITE LIGHT BLUE

## aqua DAMA

The Aqua Dama has a specially-designed specific geometry, top-class features and an attractive appearance, and it is very affordable. It has four main characteristics: aluminium, excellent features, lightweight and with a great appearance. We've created this range of bikes knowing that no two riders are alike, and the different colours, fittings and components of these bikes make them a great option at an affordable price.



### aqua DAMA . T23

-  ORBEA AQUA DAMA
-  ORBEA CARBON
-  SHIMANO 2300
-  ORBEA 28 BLACK
-  47/49/53/56
-  BLACK WHITE PINK

## SPECIFICATIONS

### aqua DAMA

CHARACTERISTICS	aqua DAMA . TTG	aqua DAMA . T23
<b>FRAME</b>	ORBEA AQUA DAMA	ORBEA AQUA DAMA
<b>FORK</b>	ORBEA CARBON	ORBEA CARBON
<b>CRANKSET</b>	SHIMANO TIAGRA 34x50 CT	SHIMANO 2300 34x50 CT
<b>HEADSET</b>	SEMIINTEGRATED 1 1/8	SEMIINTEGRATED 1 1/8
<b>HANDLEBAR</b>	ORBEA ROAD	ORBEA ROAD
<b>STEM</b>	ORBEA ALU	ORBEA ALU
<b>SHIFTERS</b>	SHIMANO TIAGRA	SHIMANO 2300
<b>BRAKES</b>	ORBEA PRO	ORBEA ALU
<b>REAR DERAILLEUR</b>	SHIMANO TIAGRA	SHIMANO 2300
<b>FRONT DERAILLEUR</b>	SHIMANO TIAGRA	SHIMANO 2300
<b>CHAIN</b>	SHIMANO HG53	SHIMANO HG50
<b>WHEELS</b>	SHIMANO WH-R500 BLACK	ORBEA 28 BLACK
<b>REAR COGS</b>	SHIMANO TIAGRA 12-25 9S	SHIMANO HG50 13-26 8S
<b>TYRES</b>	VITTORIA ZAFIRO 700x23	VITTORIA ZAFIRO 700x23
<b>PEDALS</b>	LOOK KEO EASY	ORBEA ROAD ALU
<b>SEAT POST</b>	ORBEA CARBON	ORBEA ALU
<b>SADDLE</b>	SELLE ITALIA X2 FLOW	SELLE ITALIA X2 FLOW

OPTIONS	aqua DAMA . TTG	aqua DAMA . T23
<b>FORK</b>	-	-
<b>CRANKSET</b>	SHIMANO TIAGRA 30x39x50 SHIMANO TIAGRA 39x52	SHIMANO 2300 30x42x52 -
<b>HANDLEBAR</b>	FLAT ORBEA OC-1 + TRIP -	FLAT ORBEA OC-1 + TRIP -
<b>STEM</b>	-	-
<b>WHEELS</b>	-	-
<b>PEDALS</b>	-	LOOK KEO EASY PEDAL



## GEOMETRY

### aqua DAMA

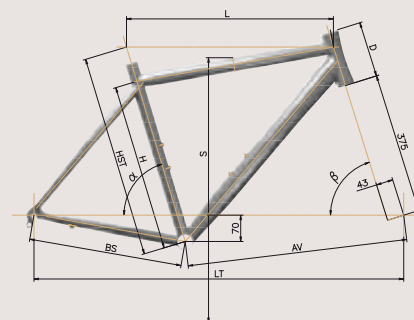

#### aqua Dama

SIZES	HST	H	L	D	BS	AV	LT	S	$\alpha$	$\beta$
47	478	410	504	92	405	575	966	716	75.2°	70°
49	490	430	510	111	405	575	970	742	74.5°	70.1°
53	530	460	525	145	405	576	971	766	74.5°	72°
56	560	490	540	165	405	576	971	793	74.5°	73.8°

## COLOURS

### aqua DAMA

WHITE LIGHT BLUE Ref: D8	BLACK WHITE PINK Ref: D9
--------------------------------	-----------------------------------



Aqua T105

Aqua TTG

Aqua T23



Aqua T105

Aqua TTG

Aqua T23